

Cheese Machinery and Solutions by

scansteel[®] foodtech



Table of Contents

Introduction	2
Cheese Industry Products	
A) Pasteurized Processed Cheese.....	4
B) Pasteurized Processed Cheese Food.....	4
C) Pasteurized Processed Cheese Spread.....	5
D) Cold Pack Cheeses.....	5
E) Cheese Sauce	6
F) Spray Dried Cheese	6
Example of Final Cheese Product - End User.....	7
Cheese & Butter Extruders MGX 250/300/400	8-9
Block and Barrel Crusher Series	
Discharge Feed Unit & Discharge Pump System for scanStructor.....	10
Whole Pallet Crushers/Breakers.....	11-15
Grinders	
Single Worm Grinders	16-21
Double Worm Grinders.....	22-25
Pumps	26-27
Cheese Pump Grinder Head	28
Final Emulsifier FE 250	29
Single Shaft Mixers	30
Twin Shaft Mixers.....	31-35
Product Transfer Equipment.....	36-41
Layout	42-43
Global Team	44-47

scansteel foodtech A/S specializes in machinery, equipment, and complete processing lines.

A Pasteurized Processed Cheese

Pasteurized Processed Cheese is typically being produced by using one or more natural cheeses that are mixed/blended with other ingredients to produce a high value final product. These kinds of cheeses typically have a smooth, creamy texture that melts without oiling off. These cheeses have a high content of natural cheese blended with other ingredients to help extend the shelf life and flavour of the product.



Example of typical applications is Queso, sauces and soups.



Example of typical applications could also be shredding of cheese into soups and/or eggs.



B Pasteurized Processed Cheese Food

Pasteurized Process Cheese Food is a product that uses a combination of natural cheeses with other dairy and non-dairy ingredients. Possibly, this product may possibly also contain a high content of natural cheese making it very flavourful and rich in taste.



C Pasteurized Processed Cheese Spread

Pasteurized Process Cheese Spread is a blend of natural cheeses and other dairy and non-dairy ingredients. This product may contain sweeteners and stabilizing ingredients to ensure lengthening of shelf life and freshness. A range of moisture levels allow for a wide variety of products such as loaves, slices, and spreads.



D Cold Pack Cheeses

Cold pack cheese products are blends of natural cheeses and other ingredients that are not cooked. The spreadable cheeses are perfect additions to crackers and veggies etc. There are countless options for flavours and types of cheese that can be used.



E

Cheese Sauce

Typically distributed as “Boil in the Bag Cheese Sauce” that can be used to spice up appetizers, pastas, and other dishes.



F

Spray Dried Cheese

Whether you produce Cheese Powders and/or Cheese Powder Blends, we feel assured that scansteel foodtech A/S has the right know-how and know-why, to find the right solution, in cooperation with your company, for your cheese processing machinery/equipment.



EXAMPLE OF FINAL CHEESE PRODUCTS - END USER

**Cheese Sticks and
Chili Cheese Tops**



Ready Meals with Cheese



Cheese Extruder Series

CHEESE & BUTTER EXTRUDER SERIES MGX 250/300/400

scansteel foodtech A/S manufactures and supplies a range of cheese extruders, model MGX 250/300/400, respectively. Extruders can be supplied as stand-alone equipment or as part of an entire cheese processing line. High output to meet high production rate demands up to 12,000 kg/hr. Lower formulation costs as high surface area/small particle size of Ø2.8/Ø5 or Ø14mm lead to increased utilisation of functional components, i.e. young cheese intact casein due to increased and consistent melting and protein hydration/emulsification capabilities. Minimum risk of foreign matter: no metal-to-metal contact surfaces because of foreign matter separation. Performance capability: high output up to 12,000 kg/hr and particle size Ø2.8, Ø5 or Ø14 mm. Capable to extrude frozen cheese and butter.



Cheese Extruder in operation.



Cheese extrusion filter comes with varied filter sizes, typically Ø2.8, Ø5 and Ø14 mm.



Close-up of extruded cheese, view 1 (one).



Close-up of extruded cheese, view 2 (two).



Close-up of extruded cheese, view 3 (three).



Front view of scansteel foodtech MGX 400 Cheese and Butter Extruder shown in production ready mode.

Cheese Extruder Series

CHEESE & BUTTER EXTRUDER SERIES MGX 250/300/400

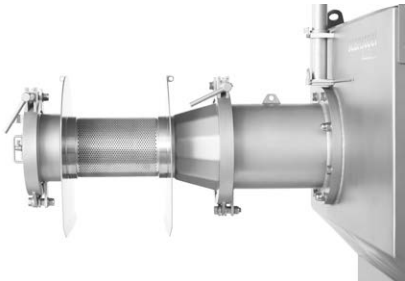

Extruder filter shown without safety cover.



Extruder filter shown with safety cover.

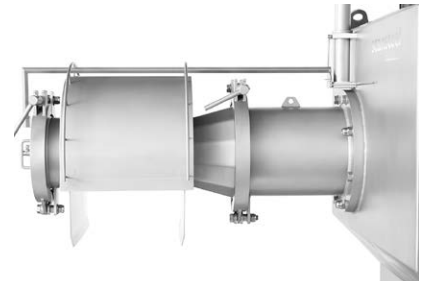

Extruder filter shown with top safety cover.



*Cheese feed guide shown right mounted.
Electro polished feeding worm/auger, also shown.*



*Assembly/
disassembly trolley
in stainless steel
execution.*



Accessory trolley for all loose parts.

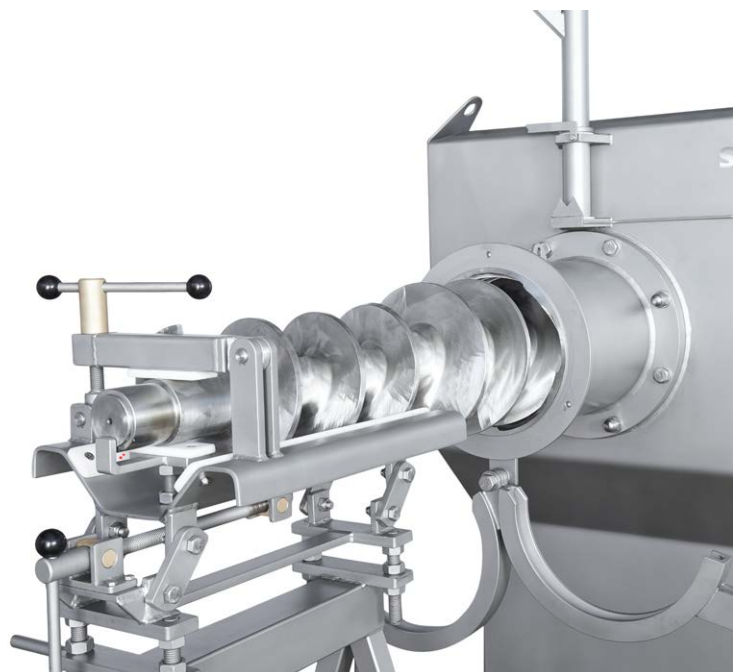

Block and Barrel Crusher Series

SCANSTEEL FOODTECH SCANSTRUCTOR

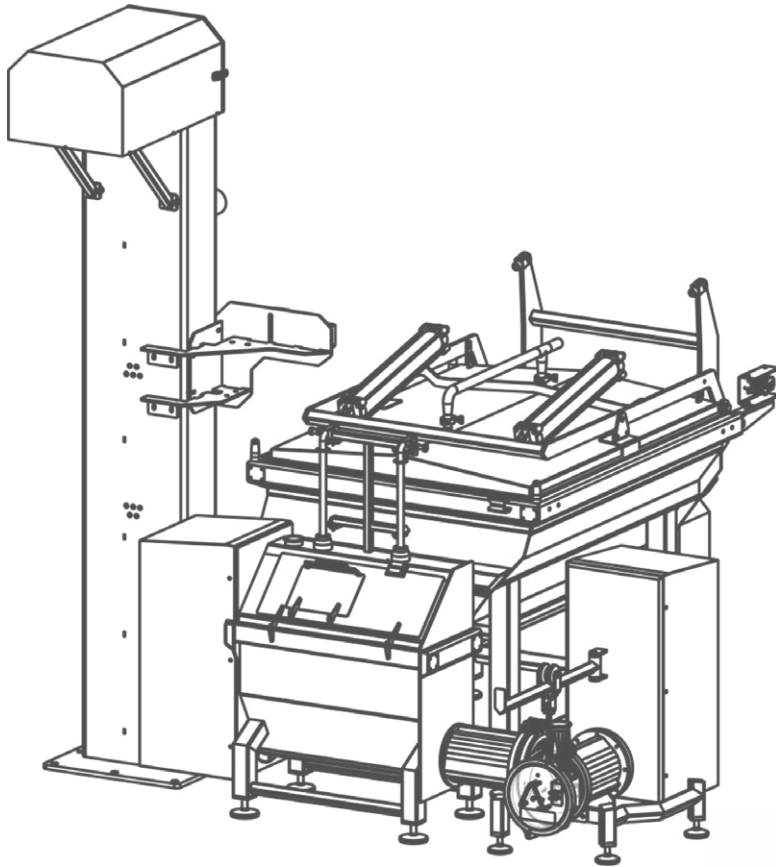

scanstructor fully assembled
- scanstructor, Discharge Feed Unit
and Discharge Pump.

scanstructor shown with pneumatic lid. Lid for
cleaning/soaking of scanstructor including CIP
(Cleaning in Place) nozzles.

Cleaning/soaking lid is delivered in 2 (two)
versions: Sliding lid or rear hinged lid.

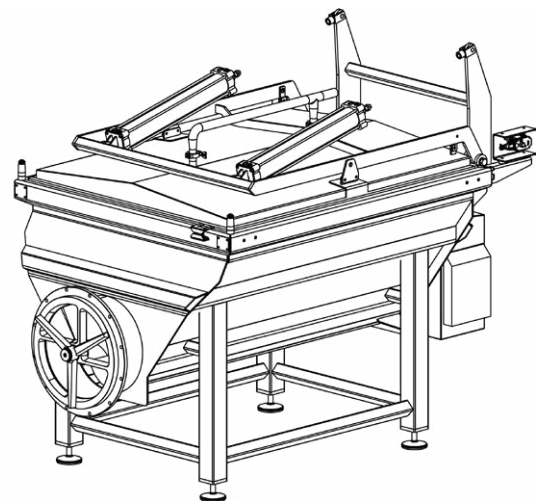

scansteel foodtech scanstructor.



Discharge Feed Unit for scanstructor.



Discharge Pump for scanstructor.

Whole Pallet Crushers/Breakers

WPC 2000-SINGLE & WPC 2000-TWIN

The scansteel foodtech Whole Pallet Crusher, WPC, range is probably among the most comprehensive ranges available. The entire cabinet and frame structure is manufactured in stainless steel AISI 304. The WPC is available with single or double rotary claw shafts. The infeed width is available in either 1500 mm or 2000 mm. The Heavy Duty design is performed with main bearing positioned on each side of the claw shaft ends thus eliminating all axial forces between the claws and gear box.



Whole Pallet Crushers/Breakers

WPC 2000-SINGLE & WPC 2000-TWIN



Bottom picture : Please note the shock absorbers which allow the WPC to remain stable (not moving) even when the WPC is fed by a fork lift truck dumping whole pallets into the crusher cabinet.



Top picture: Heavy Duty safety clutch claw and gear box.
Bottom picture: The rotary and stationary claw design comes in two versions.

SET OF STATIONARY CLAWS

Fixed onto the cabinet as counter claws to the rotary claw shaft. Each stationary claw is welded onto both sides of the rotary claw shaft.

Available Dimensions of Claw(s):	A	B
Thickness of rotary claw(s), on claw tip	65 mm	45 mm
Thickness of rotary claw(s)	60 mm	40 mm
Distance between stationary claw(s)	80 mm	60 mm

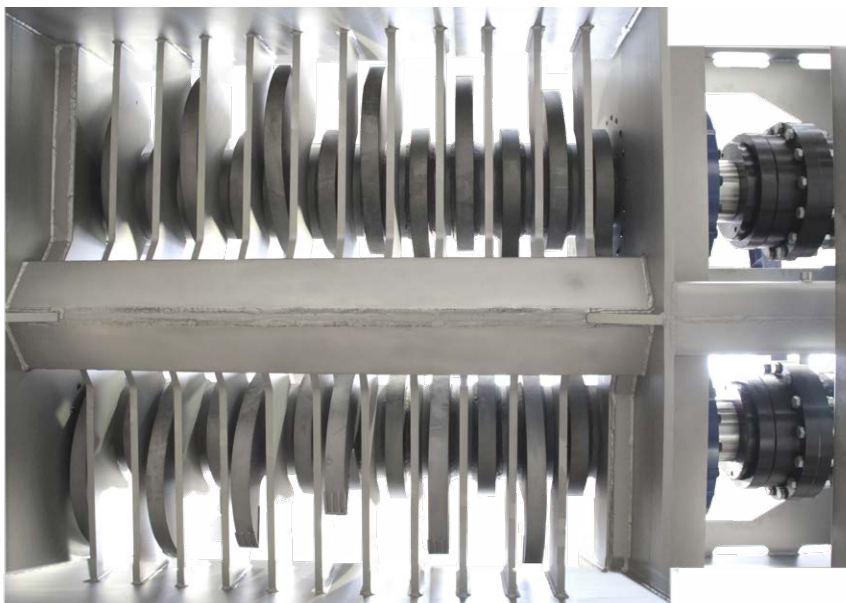

Whole Pallet Crushers/Breakers

WPC 2000-SINGLE & WPC 2000-TWIN

scansteel foodtech manufactures a range of Whole Pallet Crushers with either single claw or double claws with a standard infeed width of 2000 mm. A Whole Pallet Crusher is capable of crushing a pallet full of frozen together blocks which as such appears as one entire frozen block of, example only, 1200 x 800 x 1500 mm.



Heavy Duty bearings – on each end of the crusher claw(s). Absorbing/eliminating all axial forces between claw(s) and gear box.

The entire infeed hopper is manufactured in 20 mm stainless steel plate AISI 304.

scansteel foodtech
Whole Pallet Crusher,
WPC 2000-Single, is
shown on the picture
below.

FEATURES:

- Constructed in 20 mm stainless steel plate AISI 304.
- Infeed hopper and discharge frame/hopper manufactured according to customer requirements/demands.
- Crusher claw(s) made of hardened material.
- Designed with few spare and wear parts leading to very low operation and maintenance costs for the machine.
- Frozen block dimensions: 1000 x 1000 x 1000 mm.
- WPC 2000-Single, 10,000 – 20,000 kg/hour (22,000 – 44,000 lbs./hour) Power/motor 37 / 45 / 55 / 75 kW .
- WPC 2000-Twin, 20,000 – 60,000 kg/hour (44,000 – 130,000 lbs./hour) Power/motor 37 / 45 / 55 / 75 kW – 2 x 110 kW.
- Bearing on each end of crusher claw shaft(s).



Whole Pallet Crushers/Breakers



Crusher claw(s) made of stainless steel with hard ended claw tips. Available dimensions of claw(s) for model A & B. (Cf page 12)



Planetary gear box assembly. Between gear box and crusher claw, a Heavy Duty clutch system prevents damage to the gear box in case a large foreign (metal) object by mistake is thrown into the Whole Pallet Crusher.



scansteel foodtech Whole Pallet Crusher, WPC 2000-Single, shown in application where existing footprint is sparse and where the pre-broken frozen blocks must be elevated to approx. 5000 mm.

Below: Picture shows the 2000 mm wide inlet/ infeed hopper. The hopper is typically loaded by a fork lift truck, a lifting device, or an inclined belt conveyor.



Final installation of Whole Pallet Crusher, WPC 2000-Single, at customer site, shown with platform with ladder.



Horizontal screw shown with closed lid.

Whole Pallet Crushers/Breakers

WPC 2000-SINGLE & WPC 2000-TWIN

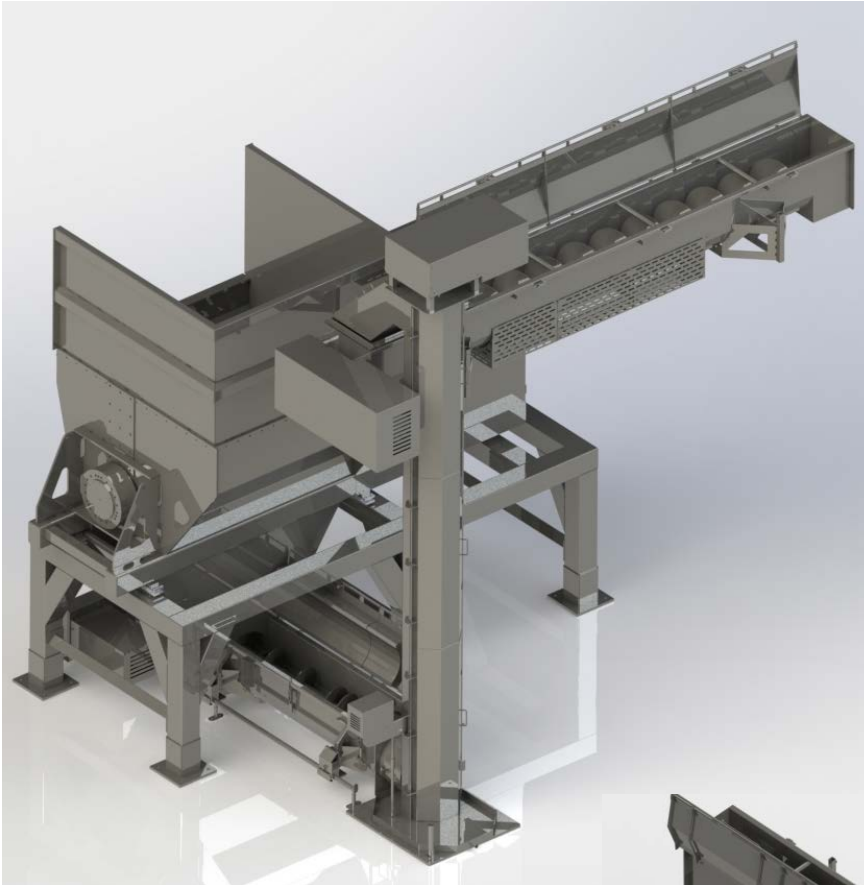

Whole Pallet Crusher, WPC 2000-Single shown with scanSuperGiraff Ø470 with discharge height of 5000 mm.

Please note the VERY small footprint needed for this solution Ideal to fit into existing manufacturing facilities.

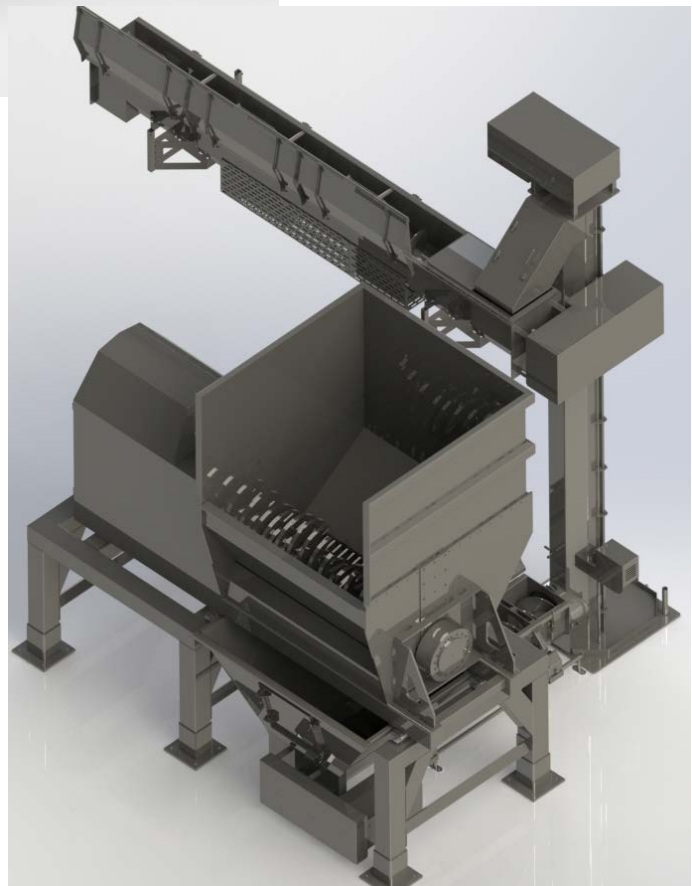

GRINDERS – SINGLE WORM

Over the years, the scansteel foodtech Group has conquered the position as THE supplier with the world's widest and most comprehensive grinder programme. scansteel foodtech delivers, among others, the following grinder programme:

- Cabinet Grinders ranging from Ø200 mm – Ø550 mm (Ø8" – Ø22") – 22 kW – 200 kW (type name: MG).
- Open Cabinet Grinders ranging from Ø200 mm – Ø550 mm (Ø8" – Ø22") – 22 kW – 200 kW (type name: MG Low).
- SuperGrind series ranging from Ø400 mm – Ø550 mm.



MG 400 Heavy Duty shown with optional flange mounted extension infeed hopper and trip wire.



MG 400 shown with safety infeed hopper with trip wire.

FEATURES:

- Constructed in stainless steel AISI 304.
- Grinders from Ø200 mm – Ø550 mm.
- Grinding capacities from 2000 – 40,000 kg/hour.
- Large hopper infeed area preventing bridge building.
- Low noise level.
- Low energy consumption.
- 75 kW – 200 kW motor.
- 1 or 2 units dismantling crane.
- Heavy Duty construction.



Infeed hopper shown from top view.

GRINDERS – SINGLE WORM: MG 400 & MG 400 HEAVY DUTY

The scansteel foodtech MG 400 & MG 400 Heavy Duty grinders are incredibly strong and reliable grinders for both frozen blocks of meat raw material of any type as well as for certain bone-in products plus fresh meat raw material. They come with either a fixed or a loose pre-cutter depending on the grinding application.

MG 400 Heavy Duty shown in disassembled position and with all loose parts positioned on accessory/ cleaning trolley for inspection and cleaning prior to assembly.

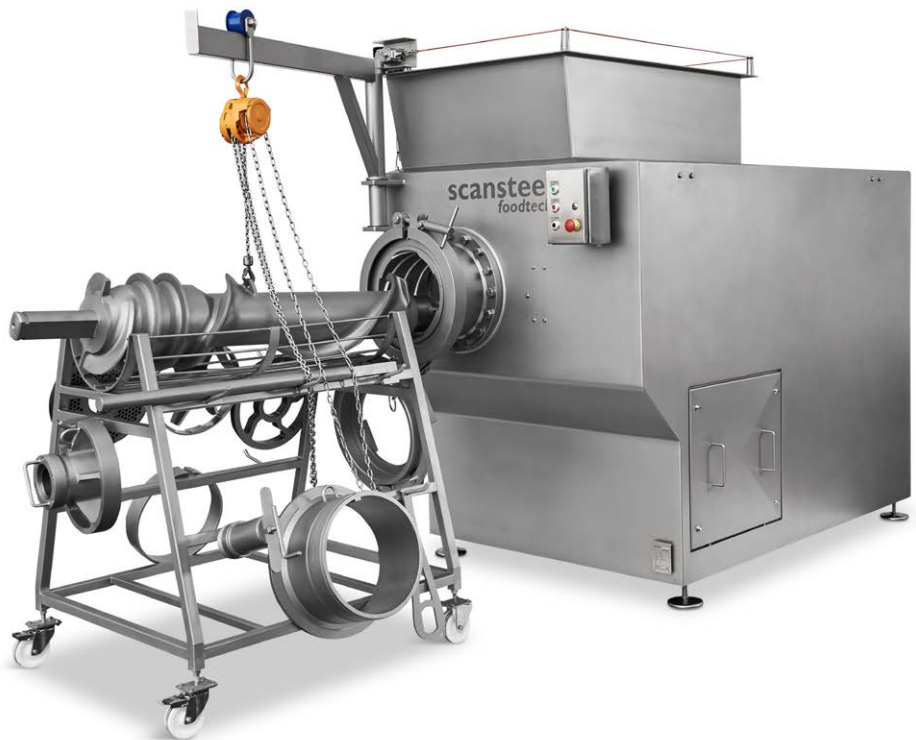

Hygienic zone shown in three positions: running position (closed) and cleaning position shown from both angles.

scansteel foodtech MG 400 Standard LOW and MG 400 Heavy Duty LOW. Without cabinet grinder. Shown with scansteel foodtech hydraulic knife tensioning system.

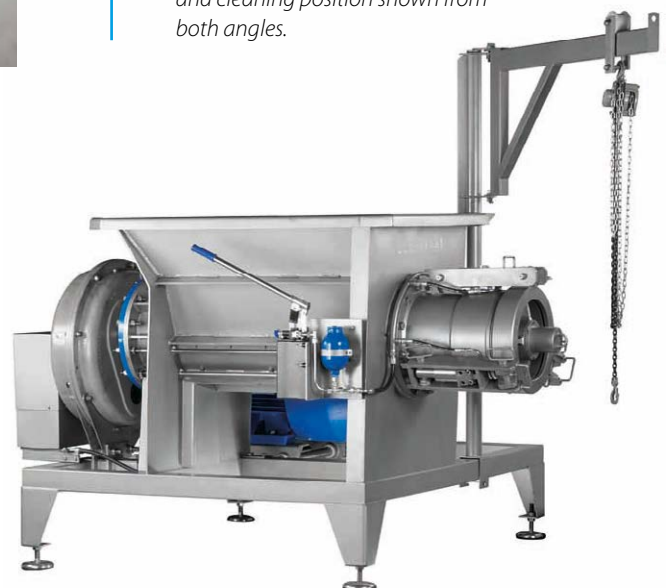

Grinders

GRINDERS – SINGLE WORM MG 400 & MG 400 HEAVY DUTY



Optional extra example only:
scansteel foodtech worm/auger.

Please note: Worm/auger is not
included in price of cleaning
trolley for worm/auger.

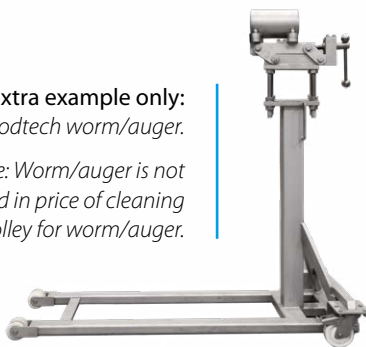

Cleaning trolley for worm/auger shown
without worm/auger.



Cleaning trolley for worm/auger shown after
the worm/auger has been removed from
grinder.

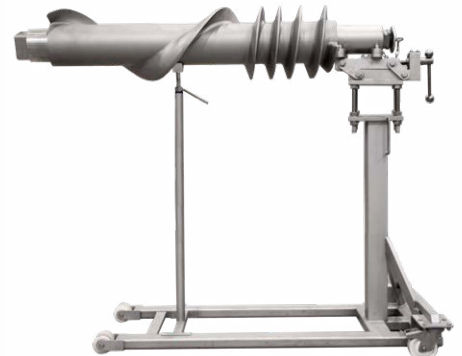

Cleaning trolley for worm/auger shown with
safety shaft mounted for cleaning, inspection,
and transport.



MG 400 worm/auger.



Heavy Duty designed worm/auger with sharp knife edge on hopper part of worm/auger to grab frozen blocks.



scansteel foodtech accessory/cleaning trolley
shown with all loose parts for inspection and
cleaning.



GRINDERS – SINGLE WORM: MG 200 & MG 250

The scansteel foodtech MG 200 & MG 250 grinders are specially designed for fresh meat and fresh meat raw materials as well as for pre-broken/crushed frozen blocks.



Infeed hopper secured by trip wire. When safety devices have been triggered, they will stop the machine after maximum 4 (four) seconds.

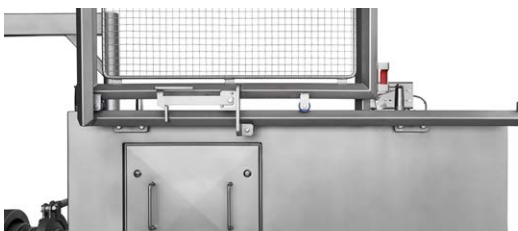

Top picture: Safety guard for platform shown in running position.
Bottom picture: Safety guard for platform shown in open/cleaning/inspection position.

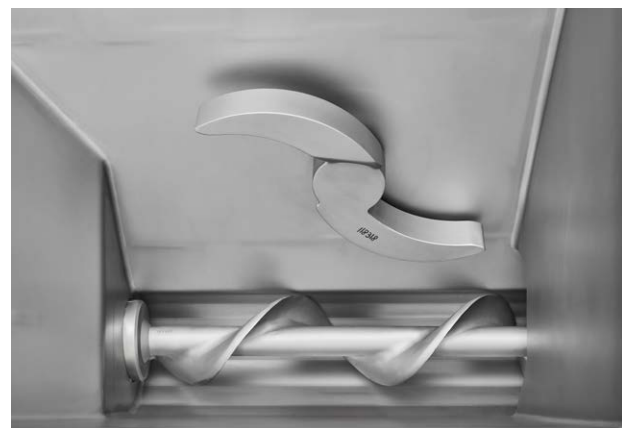

Stirring/feeding device. To secure continuous infeed of difficult/sticky meat raw material at the grinder worm/auger.

GRINDERS – SINGLE WORM: MG 200 & MG 250

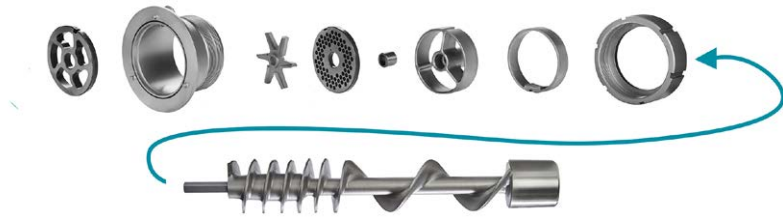

Top picture: Assembly of SINGLE knife set including grinding worm/auger.
Bottom picture: Assembly of DOUBLE knife set including grinding worm/auger.

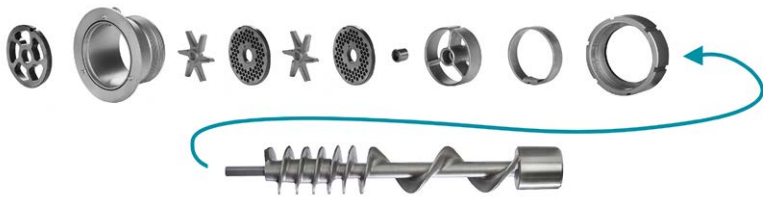

Accessory/cleaning trolley with space for all loose grinder parts.

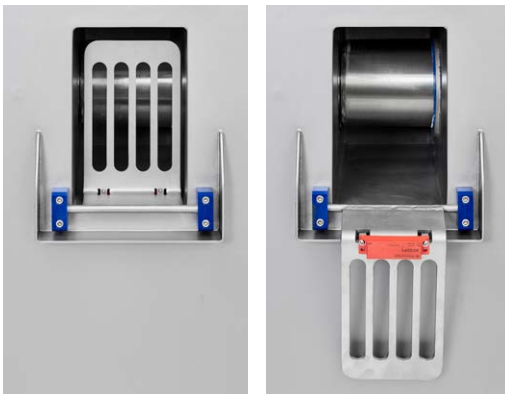

A prime example of scansteel foodtech's hygienic design is given by the hygienic zone positioned between the worm/auger and the gear box. Hygienic zone shown in running position (closed) and in cleaning/inspection position. When opened, the grinder cannot be started until the guard has been positioned in closed position.

MG 200 shown with back panel open. All stainless steel construction, including bottom frame.



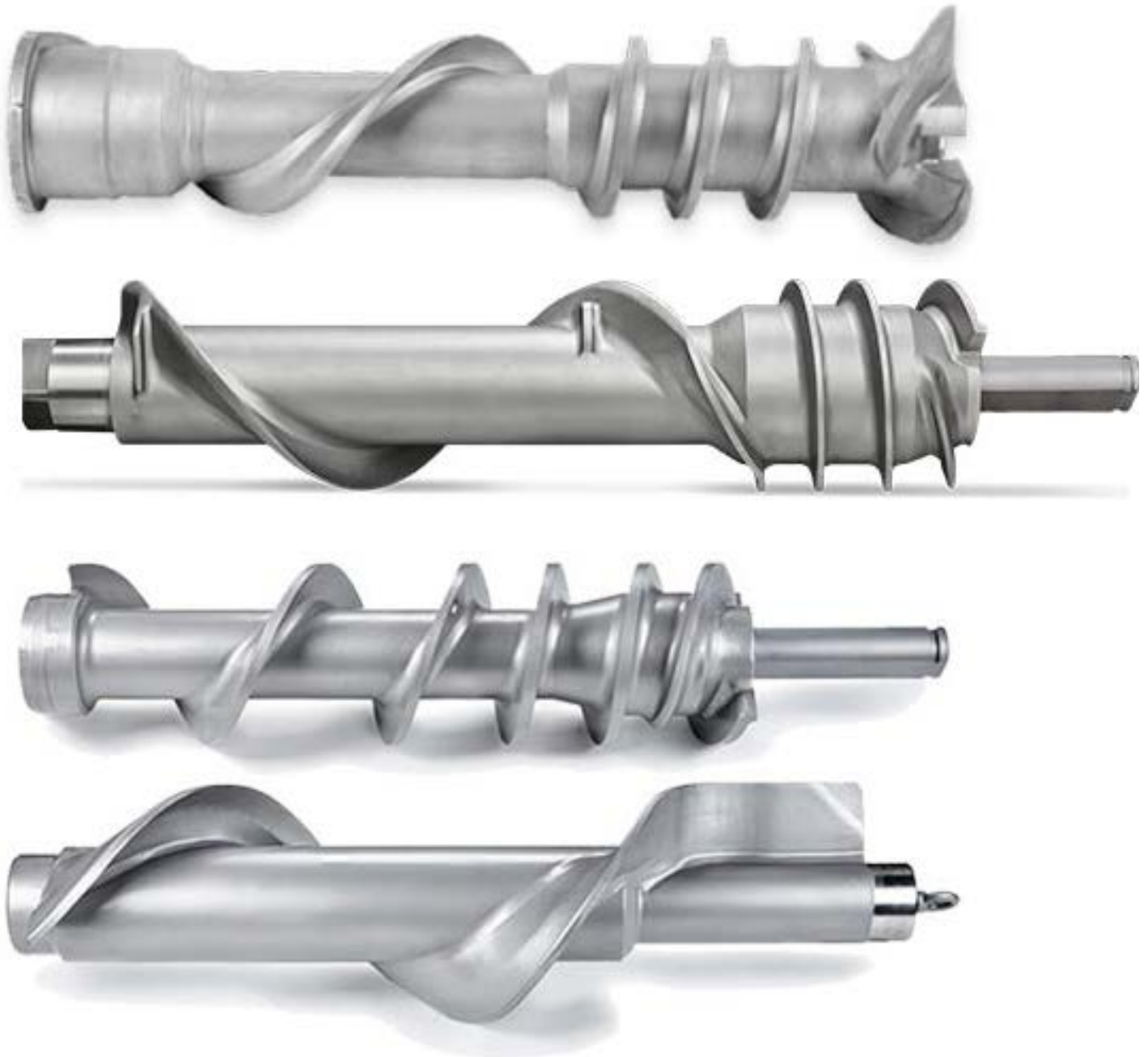

Pictures from top and down:

- SuperGrind 400/260 worm/auger.
- MG 400 worm/auger.
- CG 300 feeding/breaking worm/auger.
- CG 300 grinding worm/auger.

Grinders - Double Worm

DOUBLE WORM COMBIGRIND CG 225 / CG 300 / CG 300 HEAVY DUTY / CG 400 – THE BEAST

These truly unique and universal grinders provide first-class grinding results, fully comparable with and even surpassing those of conventionally specialised grinders for fresh, tempered, or deep-frozen blocks without changing anything but the incoming raw material to be ground, coarsely or finely, as required. CombiGrind Grinders from Ø160 mm – Ø400 mm – 11 kW – 22 kW on breaking worm/auger and 30 kW – 200 kW on grinding worm/auger (type name: CG)

CombiGrind CG 400
– The Beast



High performance grinding within a wide capacity range is achieved through a low-tolerance, rigid design with smoothly shaped worms, hand-forged, welded, and ground superfinely by skilled Danish craftsmen combined with the smooth surfaces of a high precision CNC milling lining.



DOUBLE WORM COMBIGRIND CG 225 / CG 300 / CG 300 HEAVY DUTY / CG 400 – THE BEAST



HYGIENIC ZONE

A prime example of scansteel foodtech's hygienic design is given by the two hygienic zones – one positioned between each of the worms/augers and one between the gear boxes.

Top picture: Details of the two unique hygienic zones for both top/feeding worm and bottom/grinding worm. This unique feature physically prevents cross contamination. Protected by safety grill and safety switch, which will stop the motor in three to four seconds from activation to full stop.



The electrical panel is embedded into the machine cabinet. The electrical panel can swing away to grant full access to the interior of the machine at maintenance, etc.

Grinders

COMBIGRIND CG 225 / CG 300 / CG 300 HEAVY DUTY / CG 400 – THE BEAST

CombiGrind CG 300 shown with automatic start stop of grinder by level sensors built into front legs. CombiGrind CG 300 shown with 300 L extension hopper, which will be designed according to customer request and to be quoted separately.



Fresh soft meats as well as tempered or hard frozen blocks are efficiently processed jointly or separately without changing any mechanical components due to the ingenious design of hopper, transfer area between the worms/augers combined with efficient fixation of the frozen blocks. Narrow tolerances eliminate backwash, fines, or smearing.



Operator control with easy-to-understand push button operation of start, stop, and emergency. Pre-setting of worm/auger speeds and programming functions with logically designed graphics on the touch panel. Programmes with fixed settings for various products can be keyed in with password protection. The scansteel foodtech scanControl function can be set to optimize the feeding worm/auger speed in relation to the grinding worm/auger, thus reducing grinding capacity flow fluctuations.

COMBIGRIND CG 225 / CG 300 / CG 300 HEAVY DUTY / CG 400 – THE BEAST

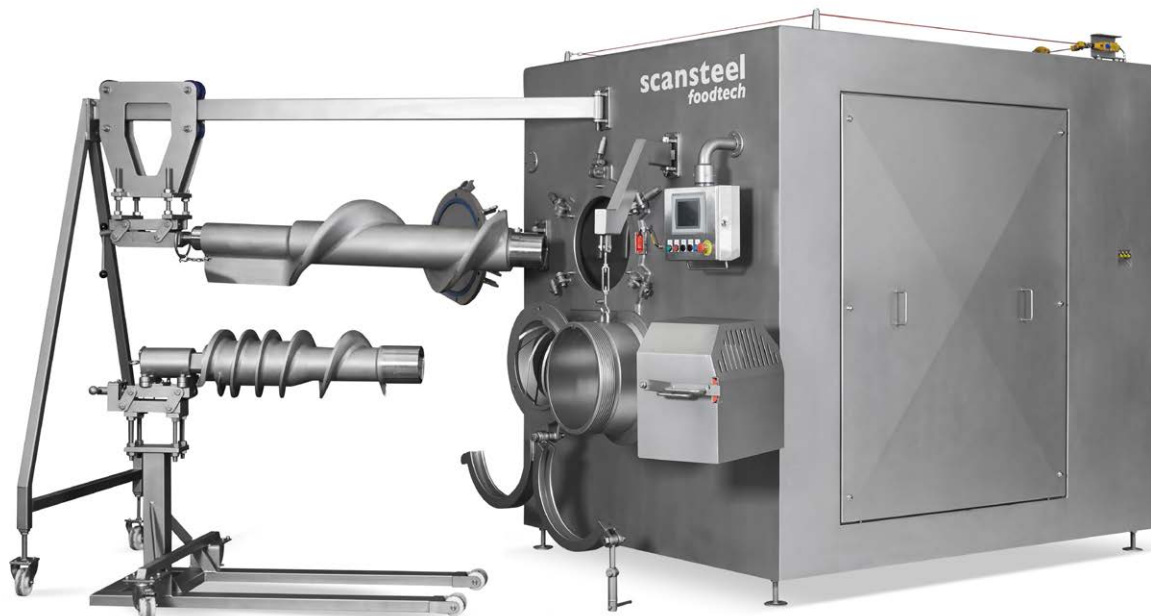

Removal of breaker worm/auger and grinding worm/auger. CombiGrind CG 400 – The Beast

Easy and efficient cleaning of both feeding worm/auger and grinding worm/auger, which can both be easily disassembled and removed together with other grinding tools by means of the included tool trolleys. Hole plates are easily removed and replaced during production with the included extraction tool, fitting the inner thread in the hole plate centre hole. The hygienic design provides easy access to and cleaning of all surfaces in contact with the product. The product area and drive components such as bearing etc. are completely separated by wide flushing channels with full visibility of and access to bearing sealings and drive clutches. This provides complete food safety as it is impossible for lubricants or bearing impurities to enter the product zone. Foldable safety fences prevent access to rotating parts during operation. All surfaces are either smoothly polished or ground and glass bead peened.



Removal of breaker worm/auger for CombiGrind CG 225, CG 300, CG 300 Heavy Duty.

Pumps

CONTIPUMPS 250/500 L – 10,000 L

The scansteel foodtech ContiPump series is for less Heavy Duty applications such as, but not limited to, pet food pre-mixes being fed into an emulsifier as well as for various buffer/storage/silo applications. The buffer hopper comes in 2 (two) versions: a single feeding screw or a twin screw hopper, where one screw feeds/drives the ContiPump and the other prevents/limits bridge building.



ContiPump 4000/250 Twin Screw shown on above picture. Shown fully assembled ready for production. Shown with all safety rails in position.

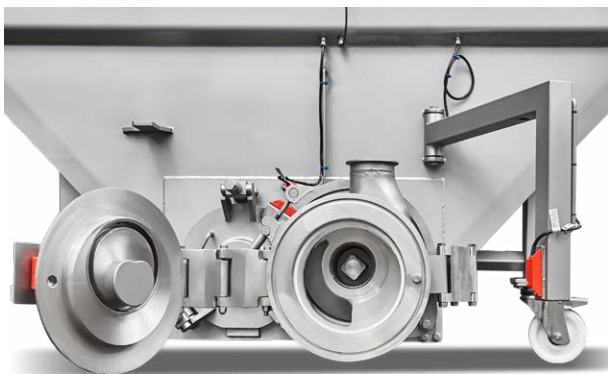

ContiPump pump housing, hinged.



Shown above: Close-up of pump housing and side panel for second screw. Both designed for easy assembly/disassembly.

Pumps

CONTIPUMPS 250/500 L – 10,000 L



ContiPump 4000/250 Twin Screw. The operator panel is shown together with a level control.

Inside view of ContiPump 4000/250 Twin Screw. Can also be supplied with top stirring device.

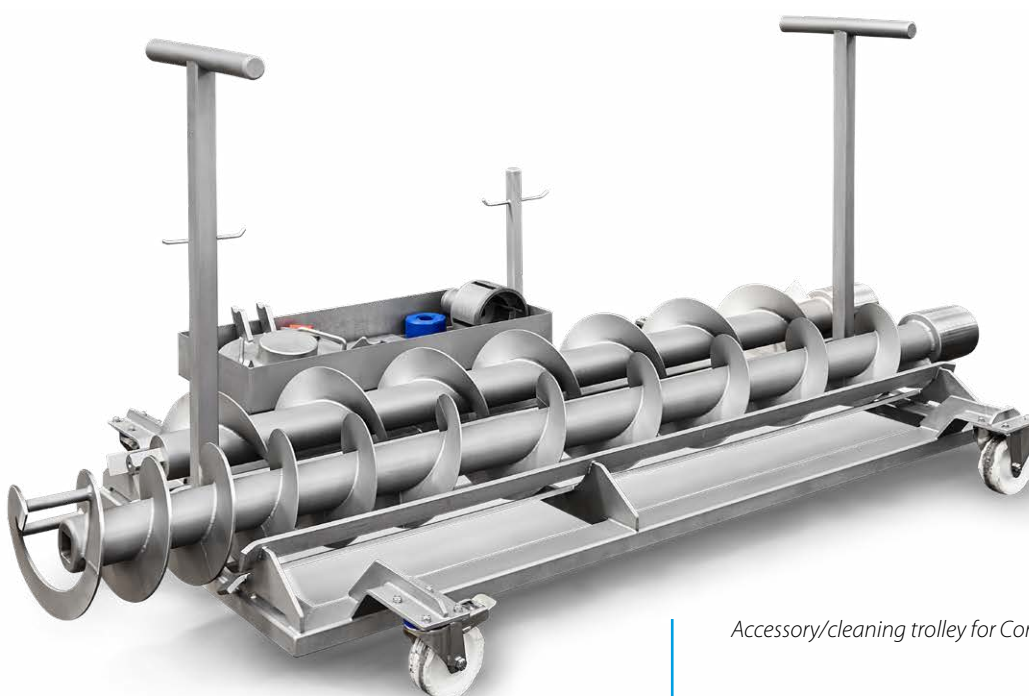

Accessory/cleaning trolley for ContiPump.

Cheese Pump Grinder Head

CHEESE PUMP GRINDER HEAD CPGH 250

*Cheese Pump Grinder Head
CPGH 250*

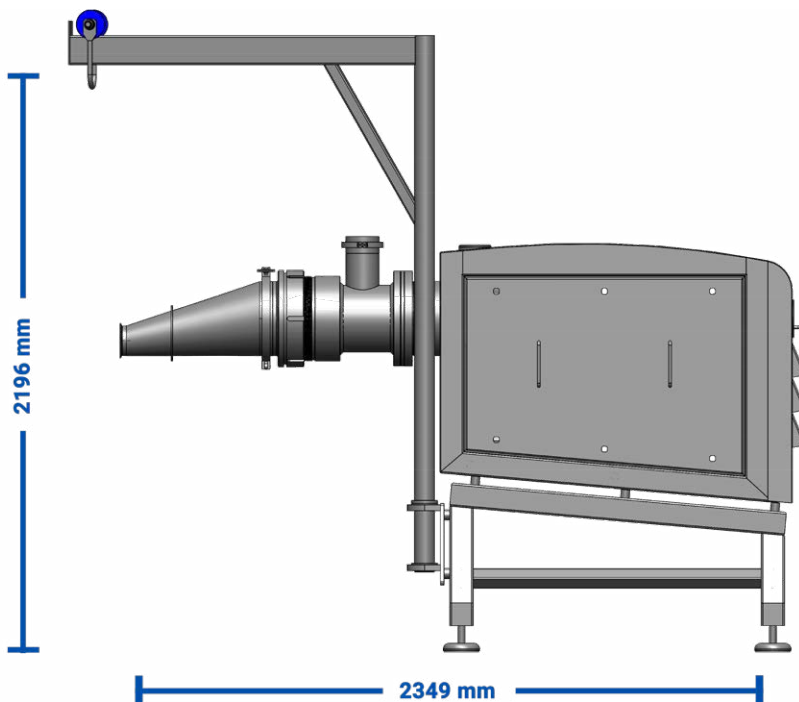

*Front view of
CPGH 250*

Final Emulsifier

SCANSTEEL FOODTECH FINAL EMULSIFIER FE 250

Final Emulsifier
FE 250.



The scansteel foodtech Final Emulsifier FE 250 is pump fed or, alternatively, fed directly by a scansteel foodtech emulsifier. The final emulsifier is typically used for final emulsifying of emulsions where particle size reduction needs to be at its maximum.

Typical motor size varies from 37 kW – 160 kW and production capacities typically vary from 4,000 – 20,000 kg/hour.



Single Shaft Mixers

SINGLE SHAFT MIXER – SSMV 1000 L - 12000 L



Single Shaft Mixer
SSMV 1000 L - 5000 L

scansteel foodtech Single Shaft Mixer SSMV 1000 L - 5000 L, 15 kW including:

- Optional vacuum included if required in process.
- Bottom steam injection system with manifold, 6 (six) nozzles.
- Plate lid with CIP nozzles (Cleaning In Place nozzles).
- Load cell system: 4 (four) unit weighing cells and PROFINET weighing amplifier.



Twin Shaft Mixers

MIXERS FROM 200 L - 12,000 L



*Twin Shaft Mixer Intermeshing,
TSMI Series.*

Our mixer programme comprises the following types and sizes:

STANDARD MIXERS	
Twin Shaft Mixers	TSM - From 200 Litres – 12.000 Litres
Twin Shaft Mixers Vacuum	TSMV – From 200 Litres – 12.000 Litres
Single Shaft Mixers	SSM – From 200 Litres – 12.000 Litres
Single Shaft Mixers Vacuum	SSMV – From 200 Litres – 12.000 Litres
INTERMESHING MIXERS	
Twin Shaft Mixers, Intermeshing	TSMI – From 200 Litres – 12.000 Litres
Twin Shaft Mixers, Intermeshing, Vacuum	TSMIV – From 200 Litres – 12.000 Litres

Features and Optional Extras

FEATURES:

- Constructed in stainless steel AISI 304.
- Safety equipment for CE conformity.
- Low energy consumption.
- Ideal for frozen meat and fresh/frozen mixtures. A flexible and high-performance mixing is given with both a high peripheral wing speed and a gentle handling of the mentioned raw materials.
- Minimum product residues and cross-mixing of batches, also including fully separated and sealed hygienic zone preventing any possible cross contamination.
- Various lid configurations: rear or side hinged. Optional as pneumatically operated.
- Computerized design of mixing wings and mixer geometry combined with the programmable mixing action ensure optimum processing results for you.
- Low noise level.
- Mixer controls available in range from ordinary push button operated versions to advanced PLC controlled systems. All PLC systems are supplied with reliable and easy accessible finger-touch operator panel with digital read-out of all mixer functions. Make Allen Bradley.

OPTIONAL EXTRAS:

- Dust lid without sealing.
- Grill lid.
- Plate lid with sealing.
- Weighing system on frame.
- Weighing system, floor mounted.
- Frame prepared for weighing system.
- Temperature sensor (incl. in CO₂ and steam) – PT100.
- CO₂ top injection system with snow horns incl. control and lid.
- CO₂ bottom injection system.
- N₂ top injection system.
- N₂ bottom injection system.
- Steam bottom injection system incl. nozzles.
- Water dosing system, automatic.
- Double jacket for heating/cooling and insulation (not pressurized).
- Polished mixing container inside meat product zone.
- Interlock for trolleys - photo cell.
- Inspection platform, various executions.
- Mixing wings optional as standard paddle or spiral wings. Standard and paddle wings to run either side-by-side or intermeshing.

Twin Shaft Mixers

MIXERS FROM 200 L - 12,000 L



*Twin Shaft Mixer, Standard
TSM Series.*

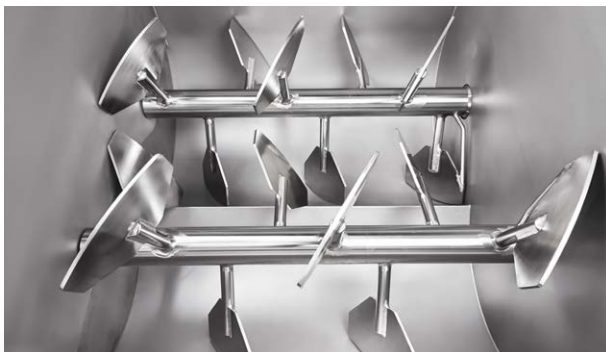

*Optional mirror polished paddle mixing wings.
Twin Shaft Mixer Intermeshing, TSMI Series.*



Large hygienic space for easy cleaning and maintenance.

Twin Shaft Mixers

TWIN SHAFT MIXER GRINDER INTERMESHING SERIES



scansteel foodtech Twin Shaft Mixer Intermeshing – TSMI Series From 400 L – 12,000 L

Rear view of mixing container showing intermeshing construction.



Optional mirror polished mixing container and mixing wings.

Side panels for easy access to the interior of the machine.



Stainless steel worm/auger and stirring device.

TWIN SHAFT MIXERS, TSM & TSMG SERIES VOLUME & DIMENSIONS CHART

To determine correct mixer size and batch size in kg when quoting a scansteel foodtech mixer please observe the following guidelines for sizes and volumes:

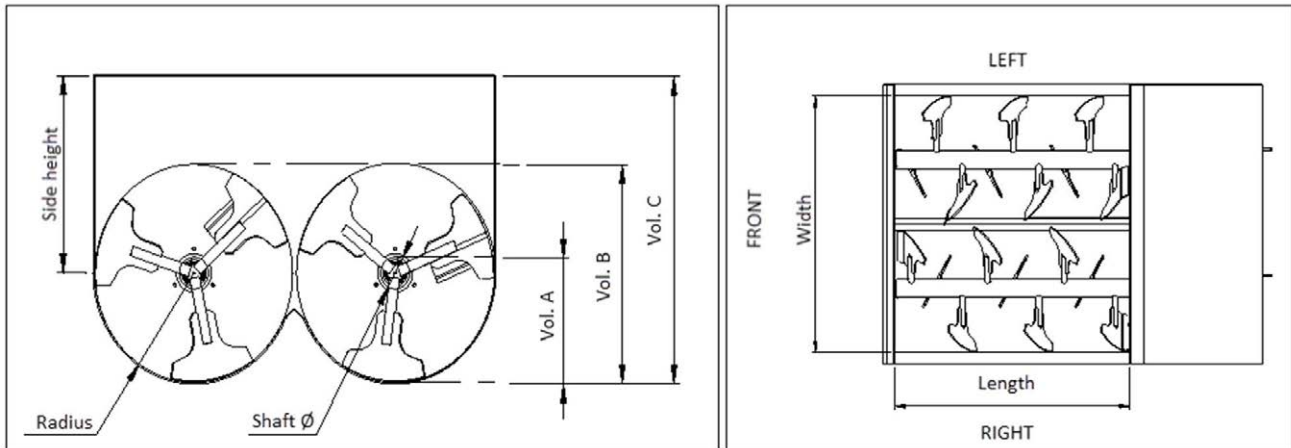

Mixers Type TSM & TSMV	Volumes, Liter			Mixer Container Inside Dimensions, mm	
	A	B	C	Length	Width
200	73	140	206	680	680
400	144	284	414	860	860
750	224	446	789	1000	1000
1250	428	851	1264	1240	1240
1750	642	1278	1860	1420	1420
2250	808	1612	2308	1540	1540
2750	975	1969	2831	1640	1640
3500	1249	2499	3579	1790	1790
4250	1494	2966	4403	1880	1880
6250	2188	3474	6225	2140	2140
7500	2598	5152	7578	2260	2260
12000	4125	8213	12203	2640	2640

Updated: June 2018/etp

Product Transfer Equipment

LOGISTIC SYSTEMS

scansteel foodtech manufactures a wide range of:

- Screw conveyors – inclined and horizontal.
- Giraff screw conveyors (horizontal/vertical as one unit).
- Vertical screw conveyors – for mounting directly on outlet of grinders.
- Lifting devices – single/double column.
- Tilt dumpers/swing loaders, hydraulic – single and double column.
- Silo buffer systems from 500 L – 12,000 L.
- Weighing and batching systems – manual or automatic dosing of pre-programmed batch sizes.



Example of inclined belt conveyor with metal detector.



Please note load cells

Weighing, unpacking, and batching tables. Table split into two units: one for unpacking of frozen blocks and one for weighing of batches. Table dimensions can be quoted and designed to customer request.



Weighing and batching station, seen from infeed side.



Weighing and batching station, seen from discharge side. Weighing belt positioned on load cells. Drip tray underneath to prevent dripping on floor.

SCREW CONVEYORS Ø240 - Ø600 MM

- INCLINED, HORIZONTAL AND VERTICAL SCREW CONVEYORS

SCREW CONVEYORS

From 1500 - 10,000 mm in length. scansteel foodtech has a full range of standard designed screw conveyors. In addition, 100% tailor-made screw conveyors, designed according to customer request, are also available. As optional extras, the scansteel foodtech range of screw conveyors can be supplied with or without hydraulic lifting and lowering systems.

Inclined screw conveyor with hydraulic knockdown system for cleaning, inspection, and maintenance purposes.



Example of infeed section for grinder.

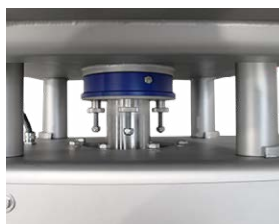

Heavy Duty shaft bearings shown.



Standard screw conveyor electrical/operator panel.



Please also note built-in drain plug for draining/cleaning purposes.



Screw conveyor in knock down position ready for inspection and/or cleaning.

SCANLIFT SINGLE COLUMN

- FULL RANGE OF STANDARD LIFTING DEVICES FOR 200 - 300 L TROLLEYS



scanLift SC 350
shown with 220 L trolley.

scanLift SC 350
shown with 300 L trolley.



scanLift SC 350 with 220 L trolley shown in
discharge position. Equipped with discharge
chute/non-spill chute.



scanLift SC 350 electrical/operator panel.

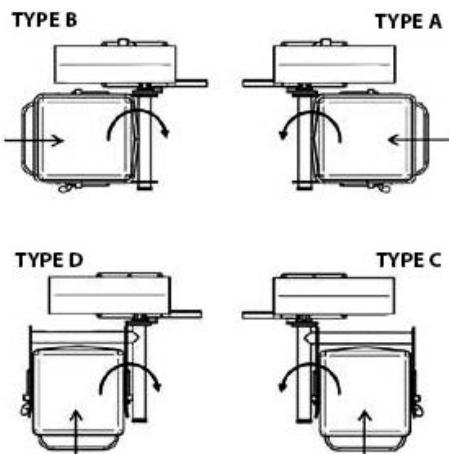

Type A and B Discharge Height in mm.	Type C and D Discharge Height in mm.
1400 – 1700	1400 – 1700
1700 – 2000	1700 – 2000
2000 – 2300	2000 – 2300
2300 – 2600	2300 – 2600
2600 – 2900	2600 – 2900
2900 – 3200	2900 – 3200
3200 – 3500	3200 – 3500
3500 – 3800	3500 – 3800
3800 – 4100	3800 – 4100

SCANLIFT SINGLE COLUMN

- FULL RANGE OF STANDARD LIFTING DEVICES FOR 200 - 300 L TROLLEYS



Special application
kettle/bowl.

i Please contact us

Please contact scansteel foodtech
for special application/lifting devices
for boxes, trolleys, and Dolav boxes.

scanLift SC 350
shown with safety cage .



Product Transfer Equipment

SCANLIFT DOUBLE COLUMN

- FOR ALL TYPES OF 220 - 300 L TROLLEYS AND BOXES/DOLAV BOXES

Double column lifting device
for plastic/metal crates/boxes.
– Dual function, shown with
plastic crates/boxes.



Double column lifting device
for plastic/metal crates/boxes.
– Dual function, shown with
200/300 L trolley.



Detail showing how forks
for 200/300 L trolley work
combined with plastic/metal
crates and boxes.

Product Transfer Equipment

SCANSWING LOADER

- SCANSTEEL FOODTECH HAS A FULL RANGE OF SWING LOADERS

scanSwing loader in down position.



scanSwing loader in discharge position.



Machine feet which can be mounted to the floor.



Operator/control panel with emergency stop.0+

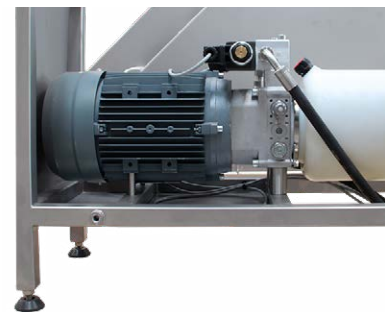

Inside view of hydraulic system.

Layout

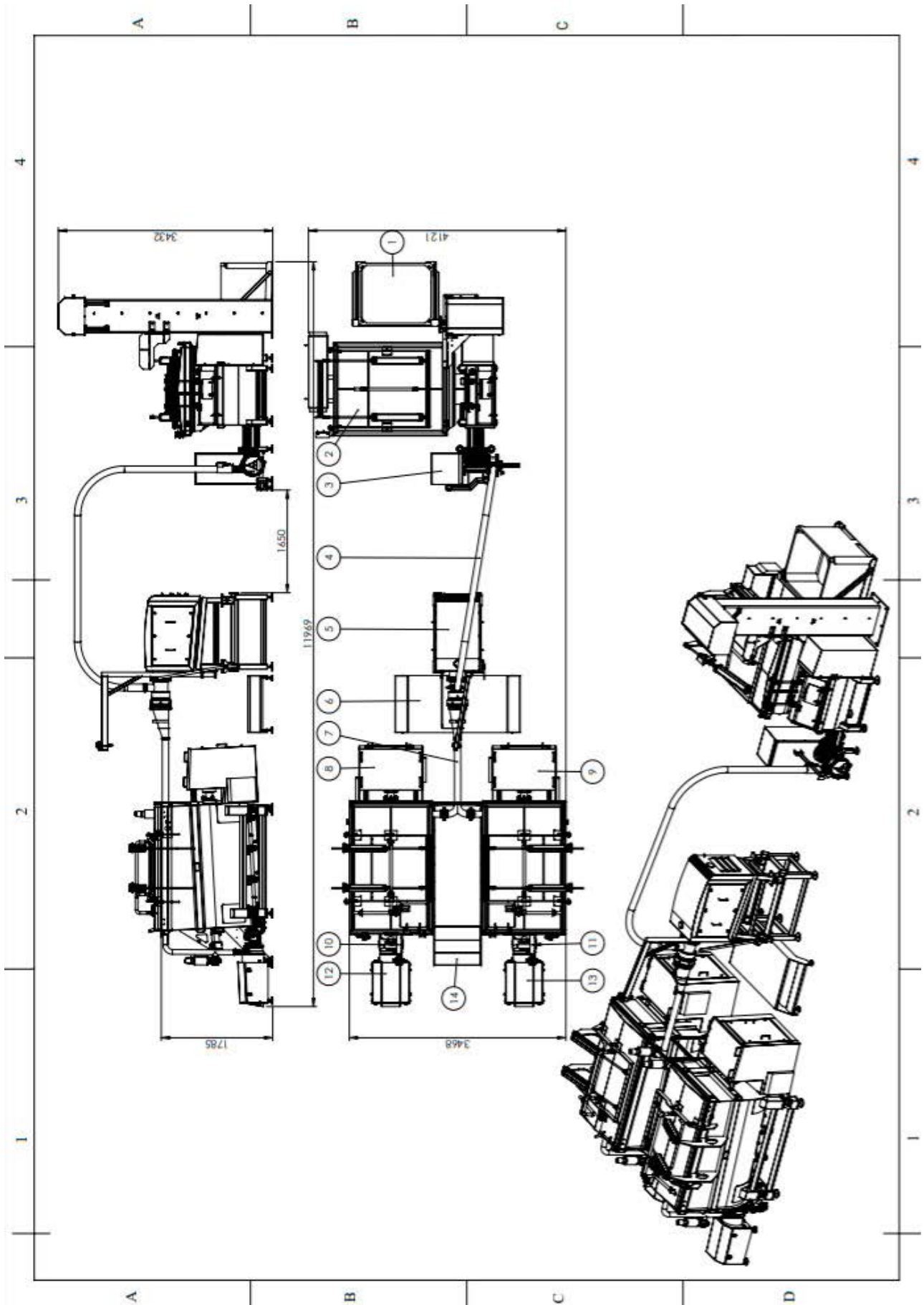

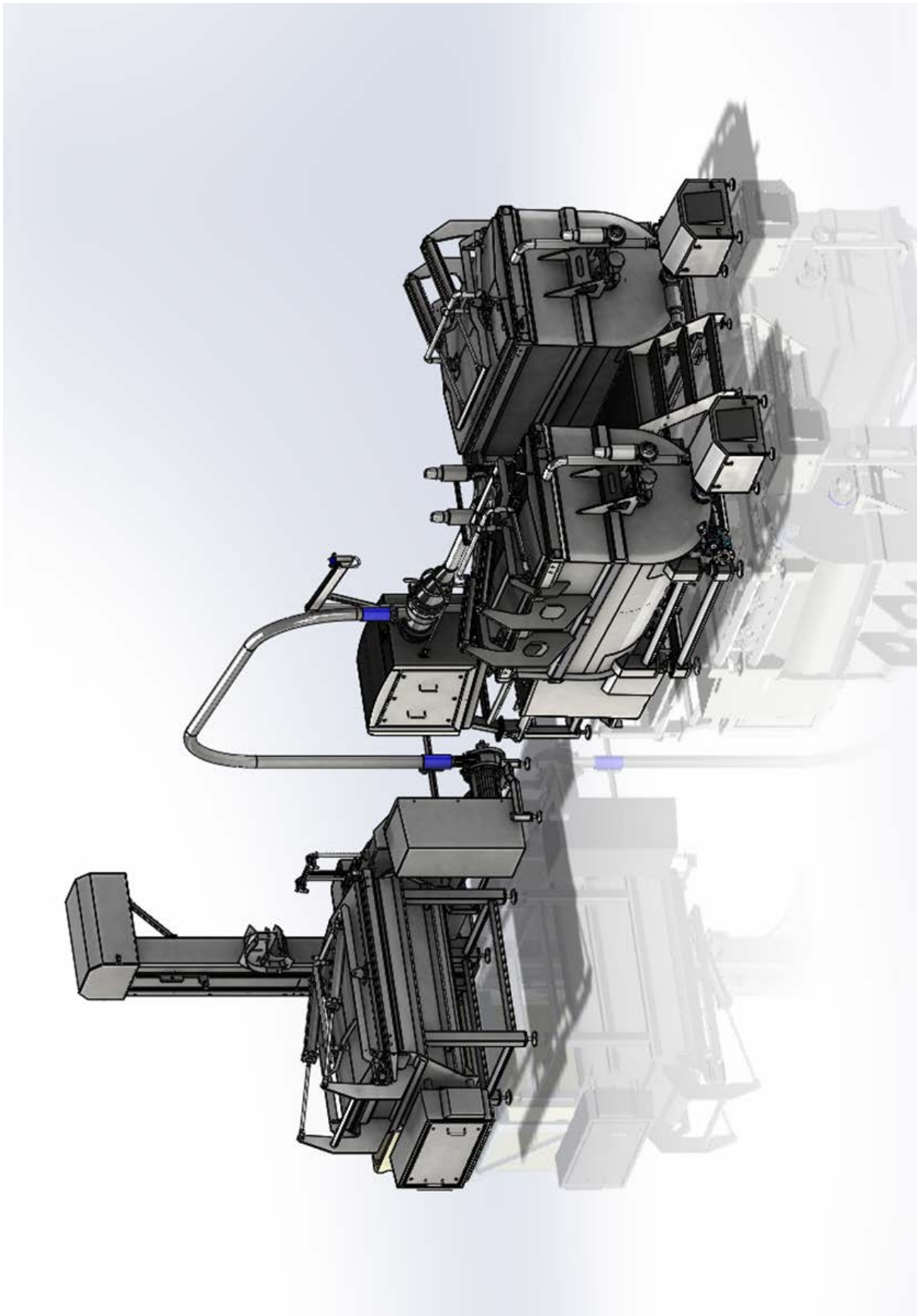

Our Global Agents & Distributors



HIGHLIGHTED BLUE AREAS SHOW GEOGRAPHIC LOCATION OF SCANSTEEL FOODTECH AGENTS AND DISTRIBUTORS.



Our Global Agents & Distributors



Jamie Culpitt
Mobile: +61 432 605 627
E-mail: jamie@focustrading.com.au
Website: www.focustrading.com.au

Darryl Russ
Mobile: +61 459 261 052
E-mail: darryl@focustrading.com.au



Dmitriy Sadovskiy
Mobile: +375 29 6394354
E-mail: dir@steiner.by
Website: www.steiner.by



Harry Jorissen
Mobile: +31 (0) 6 11867762
E-mail: harry@vertec.nl
Website: www.vertec.nl

Harold Swinkels
Mobile: +31 (0)6 5134 5188
E-mail: harold@vertec.nl



Aaron Chabino (Sales)
Phone: +1 816-880-9321
E-mail: achabino@scanamcorp.com
Website: www.scanamcorp.com

Morten Parmo (Sales)
Phone: +1 614-477-2408
E-mail: mparmo@scanamcorp.com



Bjarne Hvolbøll
Mobile: +45 20 31 38 65
E-mail: bh@nemco.dk
Website: www.nemco.dk



Mr. Pertti Laurila
E-mail: pla@nemco.fi
Website: www.nemco.fi

Bjarne Hvolbøll
Mobile: +45 20 31 38 65
E-mail: bh@nemco.dk



Laurent Castagnos
Phone: +33 (0)6 72 217 663
E-mail: l.castagnos@bfrgroupe.com
Website: www.bfrgroupe.com

Vincent Lefebvre
E-mail: v.lefebvre@bfrgroupe.com



Barry France
Mobile: +44 (0)776 696 5886
E-mail: bf@selo.com
Website: www.selo.com

Chris Keenan
Mobile: +44 (0)788 155 1420
E-mail: ck@selo.com

Our Global Agents & Distributors



Raz Pessach
Mobile: +972 (0) 52 6440 318
E-mail: raz@pessach.net
Website: www.pessach.net

Haim Rosenberg
Mobile: +972 (0) 54 245 1152
E-mail: haim@pessach.net



Andrea Lazzari
Phone: +39 045 8350877
E-mail: andrea@lazzariegquipment.com
Website: www.lazzariegquipment.com



Jose Luis Malagon
Phone: (044 81) 82 53 03 90
E-mail: jmalagon@quendalfoodtech.com



Harry Jorissen
Mobile: +31 (0) 6 11867762
E-mail: harry@vertec.nl
Website: www.vertec.nl

Harold Swinkels
Mobile: +31 (0)6 5134 5188
E-mail: harold@vertec.nl



Mike Hussey (Sales/Service Engineer)
Mobile: +64 (021) 895 330
E-mail: mike@foodmis.co.nz
Website: www.foodmis.co.nz



Odd Breigutu
Phone: +47 22 91 44 03
E-mail: odd@bokken.no
Website: www.bokken.no

Petter Breigutu
Phone: +47 22 91 44 08
E-mail: petter@bokken.no



Marcin Królicki (CEO)
Mobile +48 601 150 997
E-mail: m.krolicki@premac.pl
Website: www.premac.pl

Tomasz Mikołajczak
Phone: +48 537 721 960
Email: t.mikolajczak@premac.pl

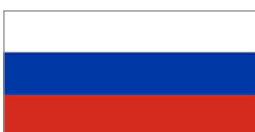

Alexander Bobrow
E-mail: aab@foodpromtech.ru
Website: www.foodpromtech.ru

Alexey Grinchuk
E-mail: ayg@foodpromtech.ru

Our Global Agents & Distributors



Rodney Macer Wright
Mobile: +27 (0) 11 466 0408
E-mail: rodney@summitpros.co.za
Website: www.summitpros.co.za



Javier Lopez
Mobile: +34 667 669 556
E-mail: javier@pics.es
Website: www.pics.es



Peo Blomqvist
Mobile: +46 (0)706 010 111
E-mail: pb@nemco.se
Website: www.nemco.se

Bjarne Hvolbøll
Mobile: +45 20 31 38 65
E-mail: bh@nemco.dk



Olexiy B. Kolodchenko
Mobile: +38 067 5061112
E-mail: olexiy@steiner.com.ua
Website: www.steiner.com.ua

Vladimir Litvinets
Mobile: +38 067 506 37 42
E-mail: vladimir@steiner.com.ua



Barry France
Mobile: +44 (0)776 696 5886
E-mail: bf@selo.com
Website: www.selo.com

Chris Keenan
Mobile: +44 (0)788 155 1420
E-mail: ck@selo.com



Aaron Chabino (Sales)
Phone: +1 816-880-9321
E-mail: achabino@scanamcorp.com
Website: www.scanamcorp.com

Morten Parmo (Sales)
Phone: +1 614-477-2408
E-mail: mparmo@scanamcorp.com



10,450 m² factory in Denmark, Headquarters of: scansteel foodtech A/S & Koncept Tech ApS

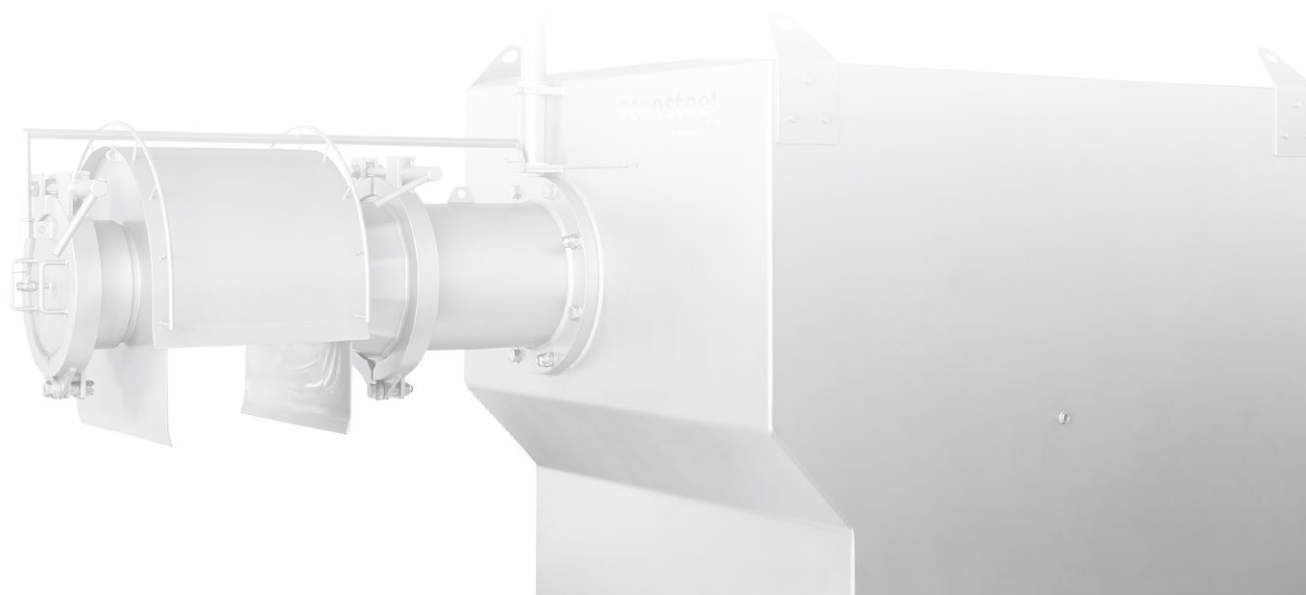

May 2020 Edition

Follow us on Social Media



scansteel foodtech



scansteel foodtech A/S



scansteel foodtech

scansteel foodtech A/S

Industrivej 6
4200 Slagelse
Denmark

Phone: +45 7027 1410

Fax: +45 7027 1411

www.scansteelfoodtech.com