

**Pet Food Machinery and Solutions by**

**scansteel<sup>®</sup>**  
**foodtech**

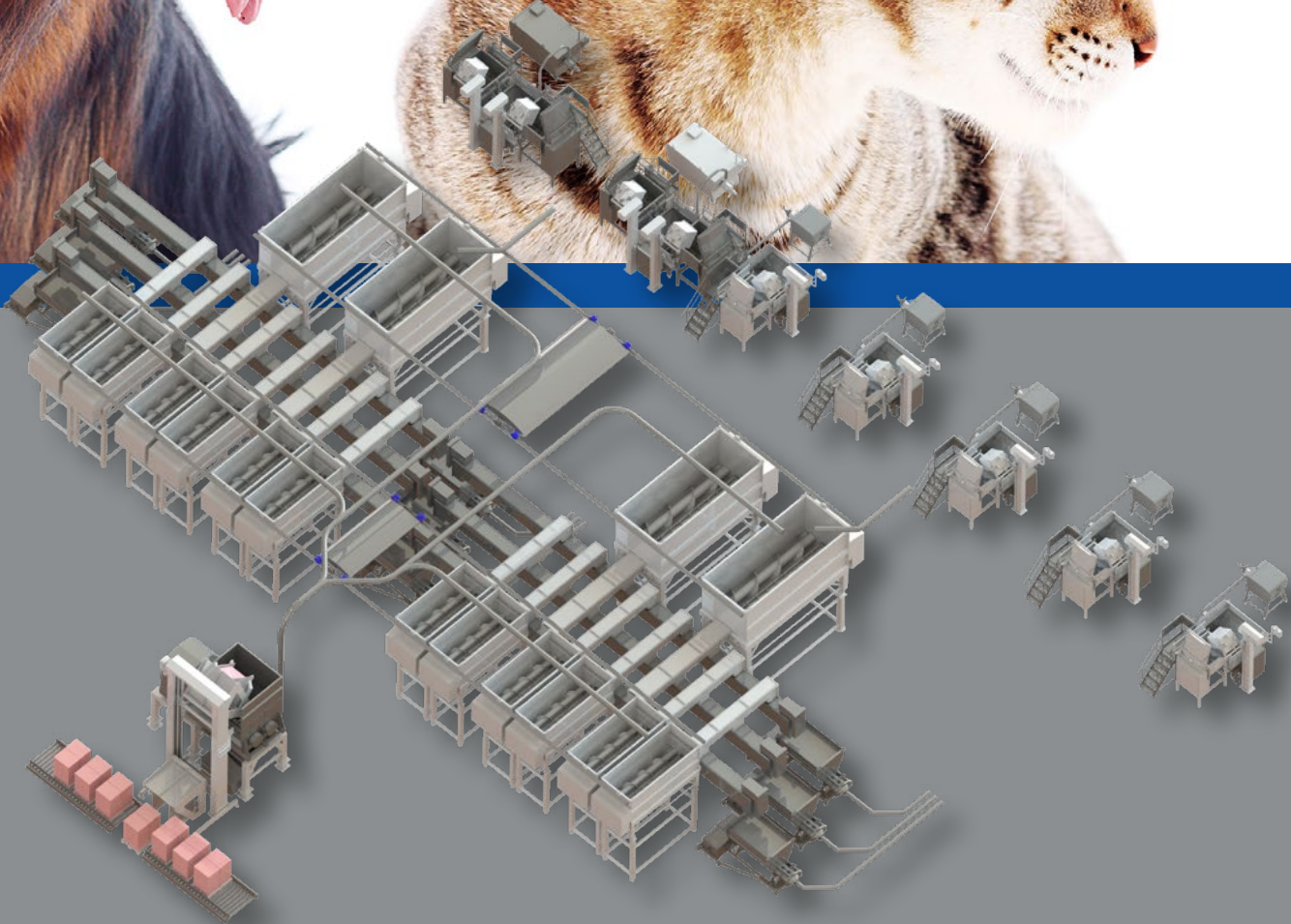

scansteel foodtech is among the leading companies globally in designing, engineering, manufacturing, installing, and servicing single machines and equipment as well as complete preparation processing lines for the global wet and dry pet food industries. Our core pet food industry competences are within the meat and bone raw material preparation segment, such as, but not limited to, whole pallet crushers, grinders for fresh and frozen meat and bone raw material, mixers, vacuum mixers, pumps for all applications, pump- and hopper-fed emulsifiers, batching and weighing stations, and silo systems for all types of Heavy Duty pet food applications.

scansteel foodtech's portfolio of standard pet food preparation machines and equipment comprises a total of approx. 140 standard machines and equipment.

In addition to our standard range of pet food preparation machines and equipment, scansteel foodtech develops individual tailor-made machines and equipment in co-operation with our customers.

Additionally, scansteel foodtech also designs, engineers, manufactures, installs, and services complete preparation processing lines. Our pet food preparation processing lines can be delivered with or without Line Control Systems, with or without recipe formulation software for uploading of data to customers' existing ERP systems and MCC's.

scansteel foodtech is a 100% privately owned Danish company (Scandinavia). scansteel foodtech resides in the former 10,450 m<sup>2</sup> Wolfking® domicile in the city of Slagelse 1 hour from Copenhagen Airport.

Feel free to contact scansteel foodtech for a mutual conversation concerning any present or future pet food preparation processing requirements you may have.



*View over scansteel foodtech final assembly hall.*

# Table of Contents

Introduction .....	2
Whole Pallet Crushers/Breakers.....	4-9
Grinders .....	10
Single Worm.....	11-17
Double Worm.....	18-19
Mixers.....	20-25
Pumps .....	26-30
Emulsifiers – Pump Fed .....	31-34
Heavy Duty Emulsifiers .....	35-36
Meat-bone separator / Deboner / Desinewer.....	37
Gravy Production Systems .....	38
Product Transfer Equipment.....	39-47
Line Control System .....	48
Layout .....	49-51
Global Team .....	52-54

Danish quality  
equipment conceived,  
engineered, and  
manufactured in  
Denmark

# Whole Pallet Crushers/Breakers

## WPC 2000-SINGLE & WPC 2000-TWIN

The scansteel foodtech Whole Pallet Crusher, WPC, range is probably among the most comprehensive available. The entire cabinet and frame structure is manufactured in stainless steel AISI 304. The WPC is available with single or double rotary claw shafts. The infeed width is available in either 1500 mm or 2000 mm. The Heavy Duty design is performed with main bearing positioned on each side of the end of the claws shaft thus eliminating all axial forces between the claws and gear box.



# Whole Pallet Crushers/Breakers

## WPC 2000-SINGLE & WPC 2000-TWIN



Please note the shock absorbers which allows the WPC to remain stable (not moving) even when

The WPC is fed by a fork lift truck dumping whole pallets into the crusher cabinet



Top picture: Heavy Duty safety clutch claw and gear box. Bottom picture: The rotary and stationary claw design comes in two versions,

### SET OF STATIONARY CLAWS

Fixet onto the cabinet as counter claws to the rotary claw shaft. Each stationary claw, made of Hardox, is welded onto both sides of the rotary claw shaft.

Available Dimensions of Claw(s):	A	B
Thickness of rotary claw(s), on clap tip	65 mm	45 mm
Thickness of rotary claw(s)	60 mm	40 mm
Distance between stationary claw(s)	80 mm	60 mm



# Whole Pallet Crushers/Breakers

## WPC 2000-SINGLE & WPC 2000-TWIN

scansteel foodtech manufactures a range of Whole Pallet Crushers with either single claw or double claws with a standard infeed width of 2000 mm. A Whole Pallet Crusher is capable of crushing a pallet full of frozen together blocks and as such appears as one entire frozen block of, example only, 1200 x 800 x 1500 mm.



Heavy Duty bearings – on each end of the crusher claw(s). Absorbing/eliminating all axial forces between claw(s) and gear box.

The entire infeed hopper is manufactured in 20 mm stainless steel plate AISI 304.

scansteel foodtech  
Whole Pallet Crusher,  
WPC 2000-Single,  
is shown on below  
picture.

## FEATURES:

- Constructed in 20 mm stainless steel plate AISI 304.
- Infeed hopper and discharge frame/hopper manufactured according to customer requirements/demands.
- Crusher claw(s) made of hardened material.
- Designed with few spare and wear parts leading to very low costs of operation and maintenance of the machine.
- Frozen block dimensions: 1000 x 1000 x 1000 mm.
- WPC 2000-Single, 10,000 – 20,000 kg/hour (22,000 – 44,000 lbs./hour) Power/motor 37 / 45 / 55 / 75 kW .
- WPC 2000-Twin, 20,000 – 60,000 kg/hour (44,000 – 130,000 lbs./hour) Power/motor 37 / 45 / 55 / 75 kW – 2 x 110 kW.
- Bearing on each end of crusher claw.



# Whole Pallet Crushers/Breakers



Crusher claw(s) made of mild steel with hard ended claw tips. Available dimensions of claw(s) for model A & B.



Planetary gear box assembly. Between gear box and crusher claw, a Heavy Duty safety clutch prevents damage to the gear box, example only, in case a large foreign (metal) object by mistake is thrown into the Whole Pallet Crusher.



scansteel foodtech Whole Pallet Crusher, WPC 2000-Single, shown in application where existing footprint is sparse and where the pre-broken frozen blocks need to be elevated to approx. 5000 mm.

Below: Picture shows the 2000 mm wide inlet/infeed hopper. The hopper is typically loaded by a fork lift truck, a lifting device, or an inclined belt conveyor.



Available Dimensions of Claw(s):	A	B
Thickness of rotary claw(s), on clap tip	65 mm	45 mm
Thickness of rotary claw(s)	60 mm	40 mm
Distance between stationary claw(s)	80 mm	60 mm



Final installation of Whole Pallet Crusher, WPC 2000-Single, at customer site, shown with platform with ladder.



Horizontal screw shown with closed lid.

# Whole Pallet Crushers/Breakers

## WPC 2000-SINGLE & WPC 2000-TWIN

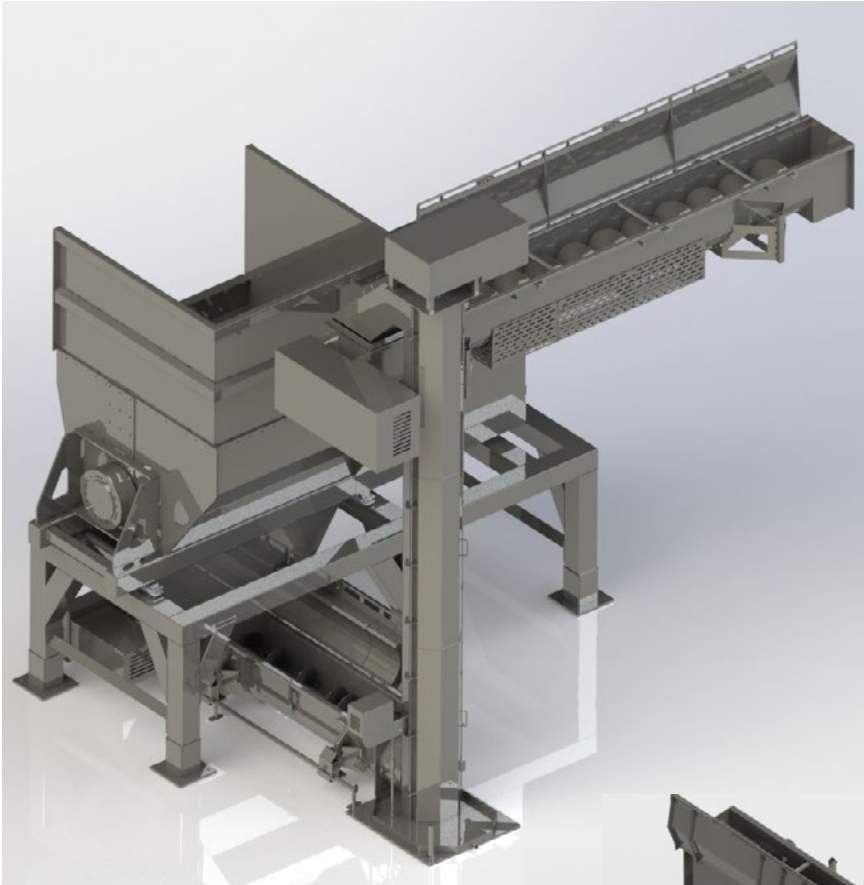

*Whole Pallet Crusher, WPC 2000-Single shown with scanSuperGiraff Ø470 with discharge height of 5000 mm.*

*Please note the VERY small footprint needed for this solution. Ideal to fit into existing manufacturing facility.*

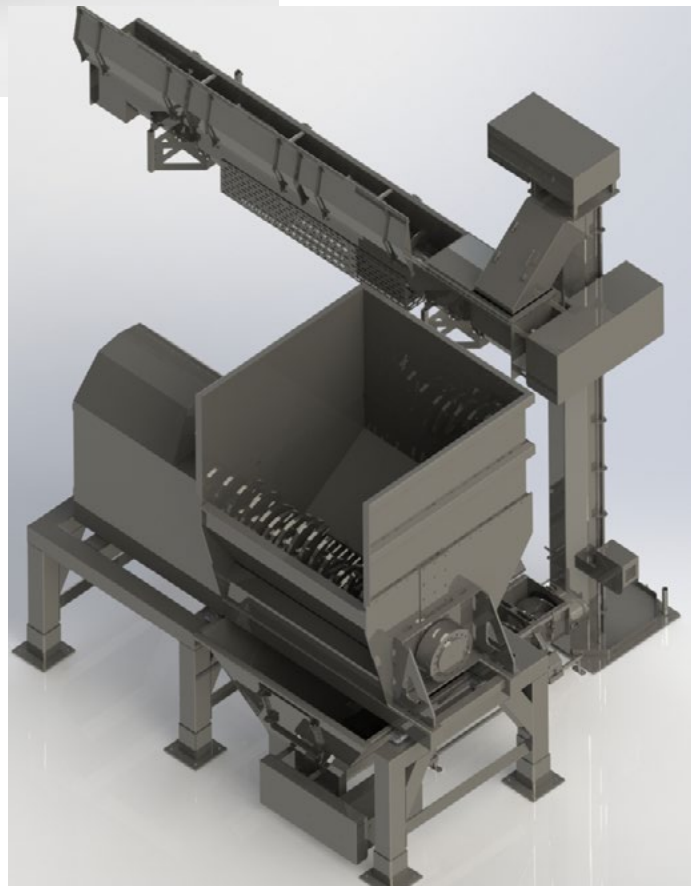



# Whole Pallet Crushers/Breakers

## WPC 2000-SINGLE & WPC 2000-TWIN

This is probably the most Heavy Duty horizontal/vertical screw conveyor available on the market. The scanSuperGiraff Ø470 mm is designed to handle PRE-CRUSHED FROZEN BLOCKS at very low temperatures running one, two or three shifts without hesitation.

*The scanSuperGiraff Ø470 mm is originally designed to be positioned right beneath a Whole Pallet Crusher, WPC 2000, Single or Double. In addition, a storage buffer silo from 1000 – 10,000 liter silo can be integrated into the scanSuperGiraff Ø470 mm.*

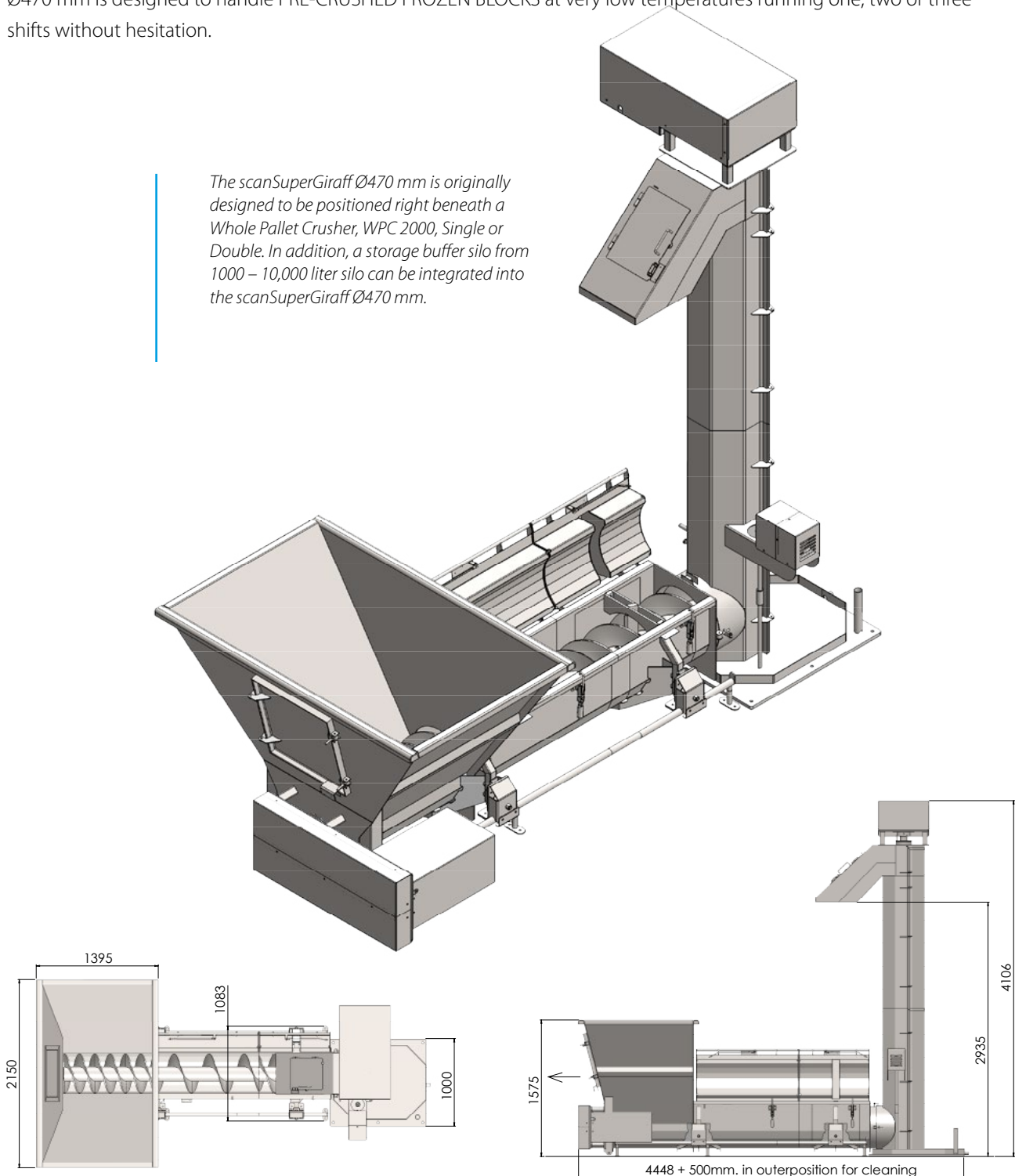

*Another design parameter is that the scanSuperGiraff Ø470 mm occupies only little footprint meaning that it can easily fit into customers' existing production room.*

# Grinders - Single Worm

## GRINDER – SINGLE WORM

Over the years, the scansteel foodtech Group has conquered the position as THE supplier with the world's widest and most comprehensive grinder programme. scansteel foodtech delivers, among others, the following grinder programme:

### Single screw grinders:

- Cabinet Grinders ranging from Ø200 mm – Ø550 mm (Ø8" – Ø22") – 22 kW – 200 kW (type name: MG).
- Open Cabinet Grinders ranging from Ø200 mm – Ø550 mm (Ø8" – Ø22") – 22 kW – 200 kW (type name: MG Low).
- SuperGrind series ranging from Ø400 mm – Ø550 mm.

### Double screw :

- CombiGrind Grinders from Ø160 mm – Ø400 mm – 11 kW – 22 kW on breaking worm and 30 kW – 200 kW on grinding worm (type name: CG).

scansteel foodtech grinders are normally used for the following applications (but not limited hereto):

- Fresh meat raw material.
- Frozen blocks of meat raw material.
- Pre-crushed/broken whole pallets of frozen blocks.
- Bones – beef, pork, poultry, fish, etc.
- Fat – all types and temperatures.
- Fish – all types.
- Fish offal.
- By-products.

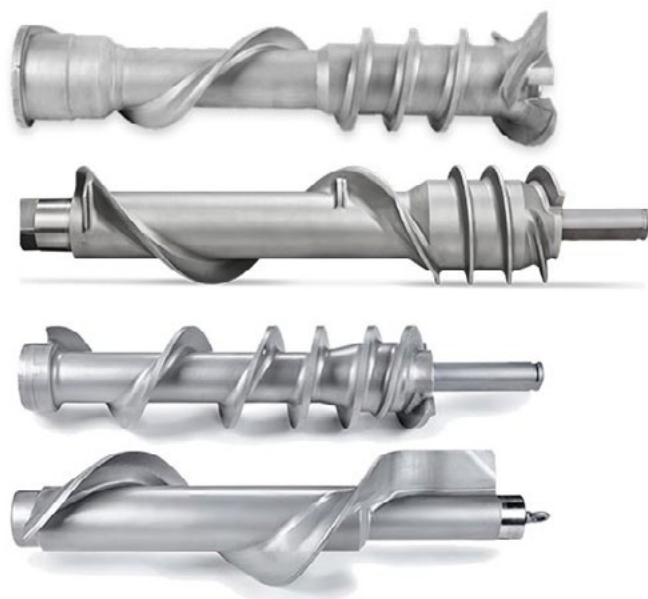

Picture to the left – from top and down:

- SuperGrind 400/260 worm/auger.

- MG 400 worm/auger.

- CG 300 feeding/breaking worm/auger.

- CG 300 grinding worm/auger.

## GRINDER – SINGLE WORM: MG 400 & MG 400 HEAVY DUTY

The scansteel foodtech MG 400 & MG 400 Heavy Duty grinder is an incredibly strong and reliable grinder for both frozen blocks of meat raw material of any type as well as for certain bone-in products plus fresh meat raw material. It comes with either a fixed or a loose pre-cutter depending of the grinding application.



*MG 400 Heavy Duty shown with optional flange mounted extension infeed hopper and trip wire*

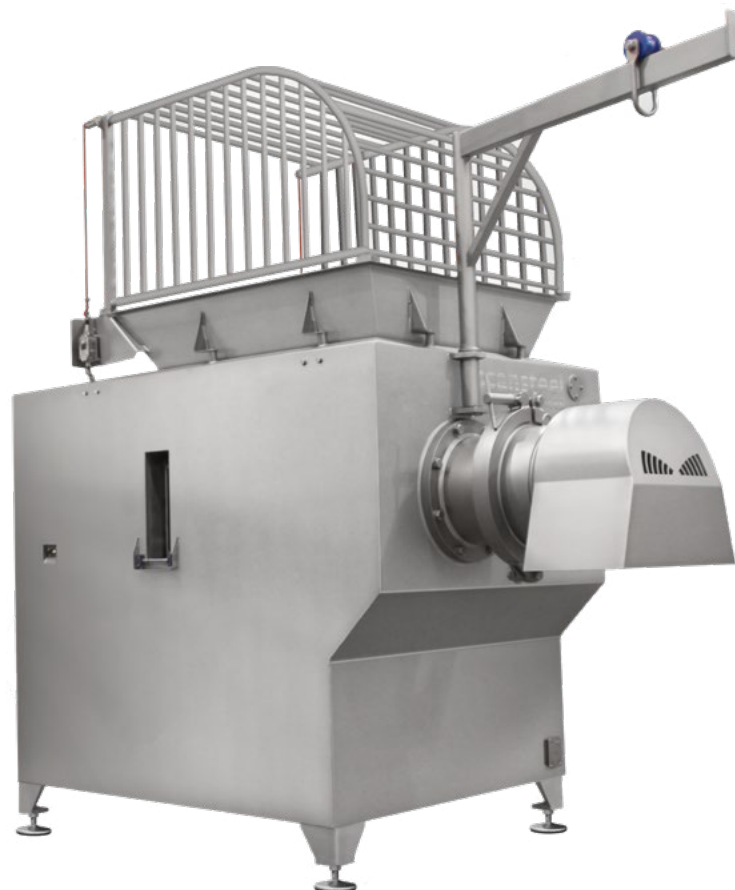

*MG 400 shown with safety infeed hopper with trip wire*

### FEATURES:

- Constructed in stainless steel AISI 304.
- Grinders from Ø200 mm – Ø550 mm.
- Grinding capacities from 2000 – 40,000 kg/hour.
- Large hopper infeed area preventing bridge building.
- Low noise level.
- Low energy consumption.
- 75 kW – 200 kW motor.
- 1 or 2 units dismantling crane.
- Heavy Duty construction.

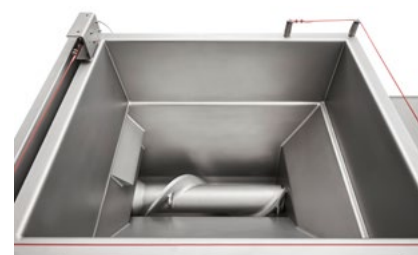

*Infeed hopper shown from top view.*

## GRINDER – SINGLE WORM MG 400 & MG 400 HEAVY DUTY

MG 400 Heavy Duty shown in disassembled position and with all loose parts positioned on accessory/ cleaning trolley for inspection and cleaning prior to assembly.



Hygienic zone shown in three positions: running position (closed) and cleaning position shown from both angles.

Optional extra example only: scansteel foodtech worm trolley.

Please note: worm is not included in price of worm trolley



Worm trolley shown without worm.

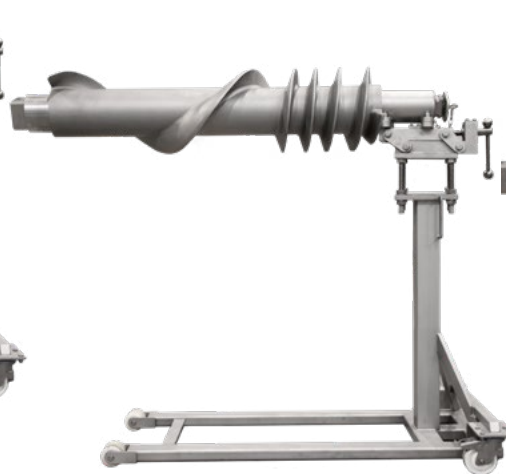

Worm trolley shown after worm is removed from grinder.

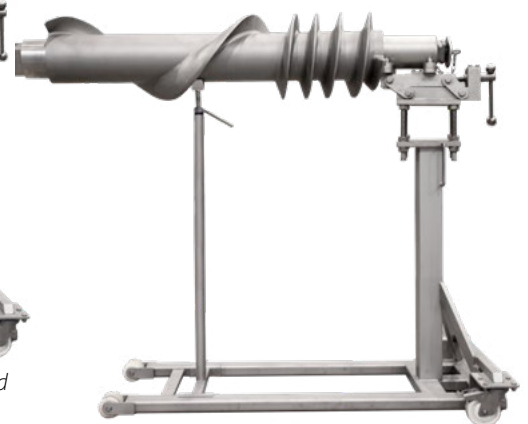

Worm trolley shown with safety shaft mounted for cleaning, inspection and transport.

# Grinders

## GRINDER – SINGLE WORM MG 400 & MG 400 HEAVY DUTY



MG 400 worm/auger



Heavy Duty designed worm/auger with sharp knife edge on hopper part of worm/auger to grab frozen blocks.



scansteel foodtech accessory/cleaning trolley shown with all loose parts for inspection and cleaning.



## GRINDER – SINGLE WORM: MG 200 & MG 250

The scansteel foodtech MG 200 & MG 250 grinders are designed specially for fresh meat and fresh meat raw materials as well as for pre-broken/chrushed frozen blocks.



*Infeed hopper secured by trip wire. Safety devices will stop the machine after maximum 4 seconds when having been triggered.*

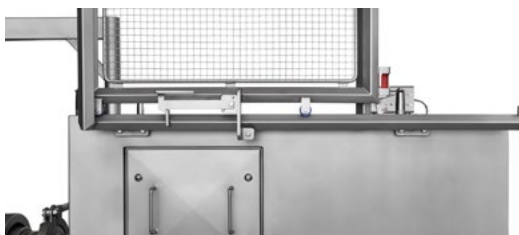

*Top picture: Safety guard for platform shown in running position.  
Bottom picture: Safety guard for platform shown in open/cleaning/inspection position.*

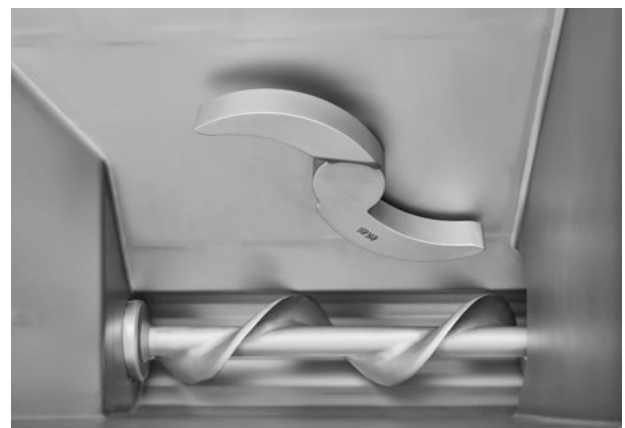

*Stirring/feeding device. To secure continuous infeed of difficult/sticky meat raw material of the grinder worm/auger.*

## GRINDER – SINGLE WORM: MG 200 & MG 250

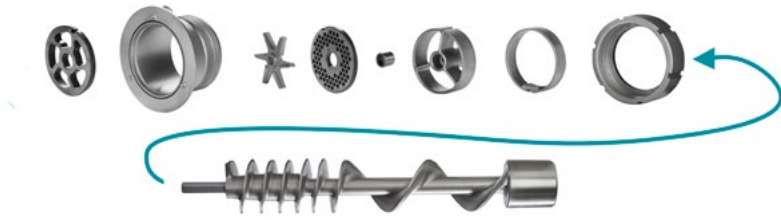

Top picture: Assembly of SINGLE knife set including grinding worm/auger.  
Bottom picture: Assembly of DOUBLE knife set including grinding worm/auger.

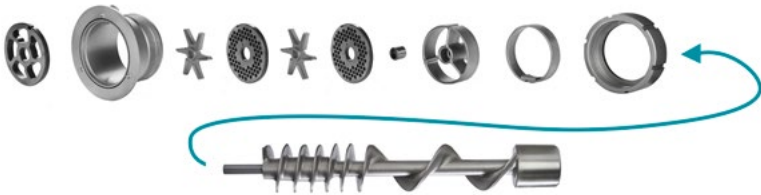

Accessory/cleaning trolley with space for all loose grinder parts.

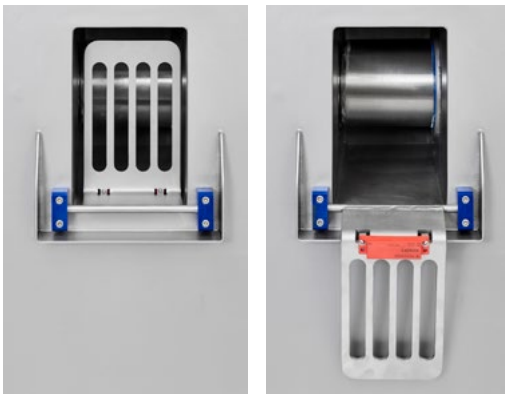

A prime example of scansteel foodtech's hygienic design is given by the hygienic zone positioned between the worm/auger and the gear box. Hygienic zone shown in running position (closed) and in cleaning/inspection position. When opened the grinder cannot be started until the guard is positioned in closed position. = When opened, the grinder cannot be started until the guard has been positioned in closed position.

MG 200 shown with back panel open. All stainless steel construction, including bottom frame.



# Grinders

## SUPERGRIND 400/260 & SUPERGRIND 550/260



*SuperGrind 400/260 shown fully assembled, ready for production. Shown with safety inlet cage to prevent meat raw material, such as frozen blocks, from being ejected during feeding of the grinder.*

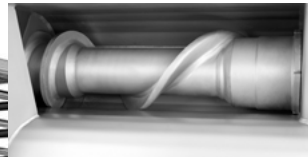

*Worm shown mounted in the SuperGrind 400/260 cabinet, top view.*



*SuperGrind 400/260 shown with all side panels dismantled, side view. Designed for easy access at maintenance and inspection. The automatic greasing system for main bearing and front bearing is also shown.*

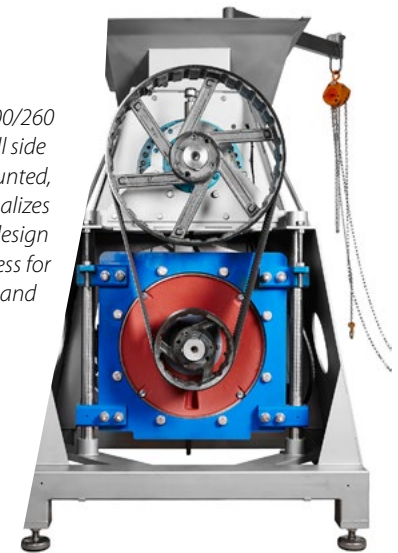

*SuperGrind 400/260 shown with all side panels dismantled, rear view. Visualizes perfectly the design with easy access for maintenance and inspection.*

Globally, the scansteel foodtech SuperGrind 400/260 & 550/260 are probably the toughest and most Heavy Duty "Work Horses" among meat raw material grinders. Designed specifically for global pet food and rendering industries for grinding of:

- Entire beef bones - all types including femur bones..
- Entire pork bones - all types including femur bones
- Poultry bones – all types.
- Fish bones – all types.
- Pre-broken bones.
- Soft meat raw material.

*The Heavy Duty design of worm for SuperGrind 400/260.*

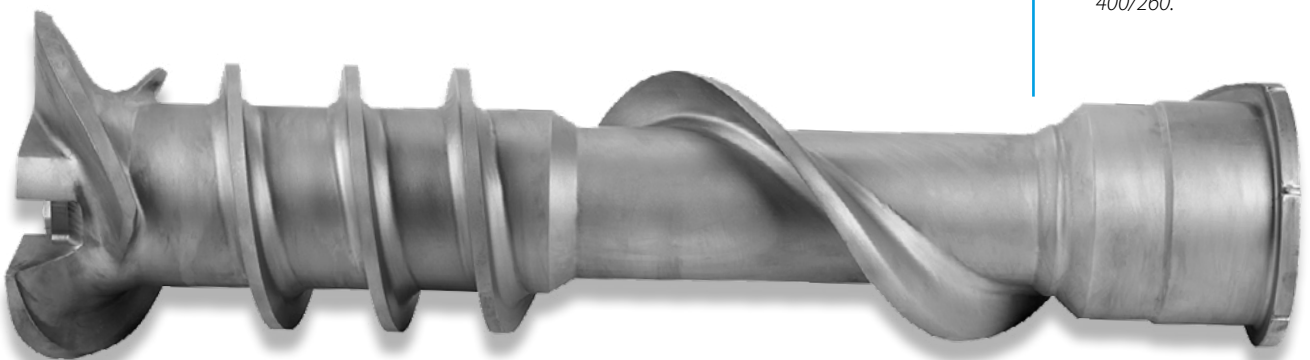



## SUPERGRIND 400/260 & SUPERGRIND 550/260



Cabinet without worm showing the flights of the lining.



Front end of SuperGrind 400/260 shown disassembled, with worm in place, ready for mounting of 3-bladed cut-knife. Cut-knife recessed into worm.



Front end of SuperGrind 400/260 shown with worm and 3-bladed cut-knife assembled.



The SuperGrind 400/260 & 550/260 can be equipped with 90 kW, 110 kW, 132 kW, or 160 kW motor.

The SuperGrind 400/260 & 550/260 can be equipped with single or double knife set.

SuperGrind 400/260 with knife set and front end fully assembled. Automatic greasing of front end bearing is shown as well.

## DOUBLE WORM COMBIGRIND CG 225 / CG 300 / CG 300 HEAVY DUTY / CG 400 – THE BEAST

These truly unique and universal grinders provide first-class grinding results, fully comparable with and even surpassing those of conventionally specialised grinders for fresh, tempered, or deep-frozen blocks without changing anything but the incoming raw material to be ground, coarsely or finely, as required.

*CombiGrind CG 400  
– The Beast*



High performance grinding within a wide capacity range is achieved through a low-tolerance, rigid design with smoothly shaped worms, hand-forged, welded, and ground superfine by skilled Danish craftsmen combined with the smooth surfaces of a high precision CNC milling lining

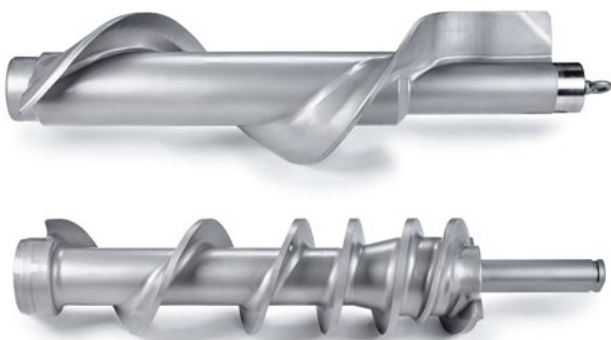

# Grinders

## DOUBLE WORM COMBIGRIND CG 225 / CG 300 / CG 300 HEAVY DUTY / CG 400 – THE BEAST

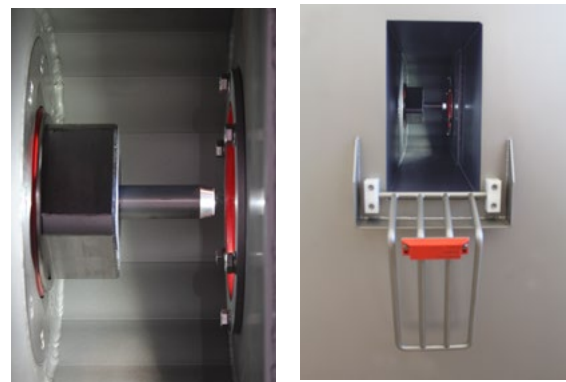

### HYGINIC ZONE

A prime example of scansteel foodtech's hygienic design is given by the two hygienic zones – one positioned between each of the worms and one between the gear boxes.

Picture above: details of the two unique hygienic zones for both top / feeding worm and bottom / grinding worm. This unique feature physically prevent cross contamination. Protected by safety grill and safety switch, which will stop the motor in three to four seconds from activation to full stop.



The electrical panel is embedded into the machine cabinet. The electrical panel can swing away to grant full access to the interior of the machine at maintenance, etc.

## COMBIGRIND CG 225 / CG 300 / CG 300 HEAVY DUTY / CG 400 – THE BEAST

*Combigrind CG 300 shown with automatic start stop of grinder by level sensors build into front legs. Combigrind CG 300 shown with 300 L. extension hopper, which will be designed according to customer request and to be quoted separately.*



*Fresh soft meats as well as tempered or hard frozen blocks are effectively processed jointly or separately without changing any mechanical components due to the ingenious design of hopper, transfer area between the worms combined with effective fixation of the frozen blocks. Narrow tolerances eliminate backwash, fines, or smearing.*



*Operator control with easy-to-understand push button operation of start, stop, and emergency. Pre-setting of worm speeds and programming functions with logically designed graphics on the touch panel. Programmes with fixed settings for various products can be keyed in with password protection. The scansteel foodtech scanControl function can be set to optimize the feeding worm speed in relation to the grinding worm, thus reducing grinding capacity flow fluctuations.*

## COMBIGRIND CG 225 / CG 300 / CG 300 HEAVY DUTY / CG 400 – THE BEAST

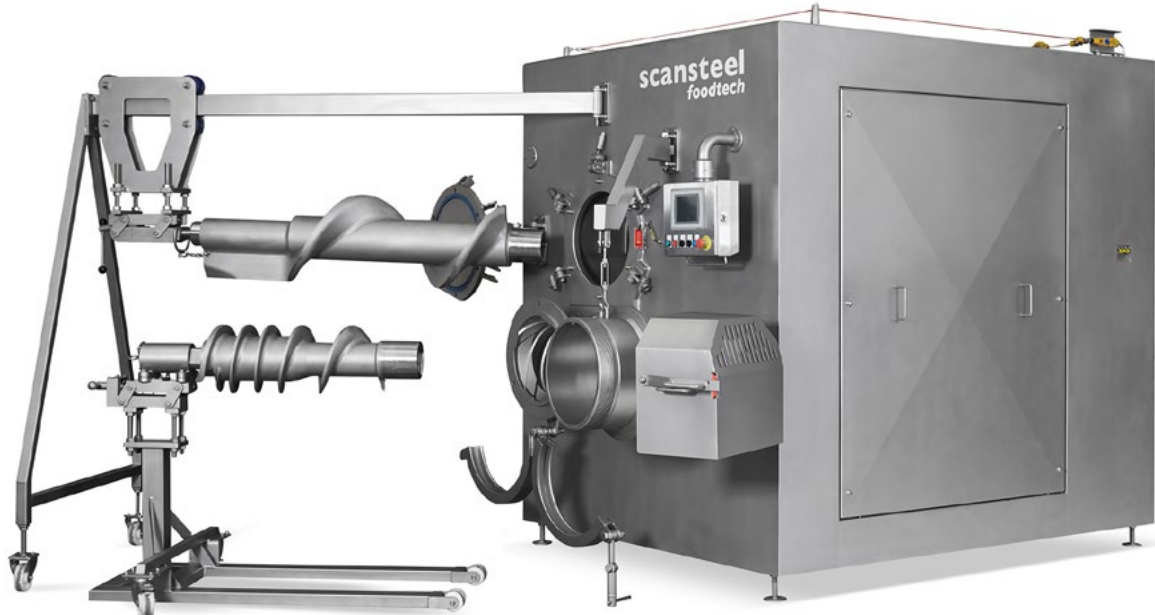

*Removal of breaker worm and grinding worm. CombiGrind CG 400 – The Beast.*

Easy and effective cleaning of both feeding worm and grinding worm, which can both be easily disassembled and removed together with other grinding tools by means of the included tool trolleys. Hole plates are easily removed and replaced during production with the included extraction tool, fitting the inner thread in the hole plate centre hole. The hygienic design provides easy access to and cleaning of all surfaces in contact with the product. The product area and drive components such as bearing etc. are completely separated by wide flushing channels with full visibility of and access to bearing sealings and drive clutches. This provides complete food safety as it is impossible for lubricants or bearing impurities to enter the product zone. Foldable safety fences prevent access to rotating parts during operation. All surfaces are either smoothly polished or ground and glass bead peened.



*Removal of breaker worm for CombiGrind CG 225, CG 300, CG 300 Heavy Duty.*

## MIXERS FROM 200 L - 12,000 L



*Twin Shaft Mixer Intermeshing,  
TSMI Series.*

scansteel foodtech supplies a full range of Mixers and Mixer/Grinders for the global food processing industry as well as the global pet food industry. Our Mixer and Mixer/Grinder programme comprises the following types and sizes:

<b>STANDARD MIXERS</b>	
Twin Shaft Mixers	TSM - From 200 Litres – 12.000 Litres
Twin Shaft Mixers Vacuum	TSMV – From 200 Litres – 12.000 Litres
Single Shaft Mixers	SSM – From 200 Litres – 12.000 Litres
Single Shaft Mixers Vacuum	SSMV – From 200 Litres – 12.000 Litres
<b>INTERMESHING MIXERS</b>	
Twin Shaft Mixers, Intermeshing	TSMI – From 200 Litres – 12.000 Litres
Twin Shaft Mixers, Intermeshing, Vacuum	TSMIV – From 200 Litres – 12.000 Litres

## MIXERS FROM 200 L - 12,000 L



*Twin Shaft Mixer, Standard  
TSM Series.*



*Optional mirror polished paddle mixing wings.  
Twin Shaft Mixer Intermeshing, TSMI Series.*



*Large hygienic space for easy cleaning and maintenance.*

## Features and Optional Extras

---

### FEATURES:

- Constructed in stainless steel AISI 304.
- Safety equipment for CE conformity.
- Low energy consumption.
- Ideal for frozen meat and fresh/frozen mixtures. A flexible and high-performance mixing is given with both a high peripheral wing speed and a gentle handling of the mentioned raw materials.
- Minimum product residues and cross-mixing of batches, also including fully separated and sealed hygienic one preventing any possible cross contamination.
- Various lid configurations: rear or side hinged. Optional as pneumatically operated.
- Computerized design of mixing wings and mixer geometry combined with the programmable mixing action secure optimum processing results for you.
- Low noise level.
- Mixer controls available in range from ordinary push button operated versions to advanced PLC controlled systems. All PLC systems are supplied with reliable and easy accessible finger-touch operator panel with digital read-out of all mixer functions. Make Allen Bradley



## Features and Optional Extras

---

### OPTIONAL EXTRAS:

- Dust lid without sealing.
- Grill lid.
- Plate lid with sealing.
- Weighing system on frame.
- Weighing system, floor mounted.
- Frame prepared for weighing system.
- Temperature sensor (incl. in CO2 and steam) – PT100.
- CO2 top injection system with snow horns incl. control and lid.
- CO2 bottom injection system.
- N2 top injection system.
- N2 bottom injection system.
- Steam bottom injection system incl. nozzles.
- Water dosing system, automatic.
- Double jacket for heating/cooling and insulation. (not pressurized).
- Polished mixing container inside meat product zone.
- Interlock for trolleys - photo cell.
- Inspection platform, various executions.
- Mixing wings optional as standard, paddle or spiral wings. Standard and paddle wings to run either side-by-side or intermeshing.

## SUPERPUMPS SP 200 / SP 250 / SP 290

The scansteel foodtech SuperPump series comprises 3 (three) different pump sizes. Correct choice of pump depends on several factors such as, but not limited to, pump capacity, material to be pumped, temperature, viscosity, and particle size – from pre-ground meat raw material to half a pork carcass. One significant feature is the double discharge outlet which dramatically minimizes (eliminates) fluctuations in pump capacity. Motor for pumps is designed according to pump application.

### 1 Infeed Buffer / Hopper Solution

*Example of scansteel foodtech SuperPump 2500 L silo/buffer hopper with stirring/feeding device with SuperPump 200.*



*2500 L silo/buffer hopper with stirring/feeding device. The stirring device feeds products to the centre for discharge into SuperPump 200.*



*The transmission of a SuperPump consists of individual planetary gear box and electric motor.*



*Pump transmission.*

## SUPERPUMPS SP 200 / SP 250 / SP 290

### 2 Infeed Buffer / Hopper Solution

Example of scansteel foodtech SuperPump 290 with small infeed hopper. Suited for pump applications where sparse footprint is available.



SuperPump 290 infeed hopper shown with rotating feeding device for feeding screw

### 3 Infeed Buffer / Hopper Solution

SuperPump290 with storage buffer hopper and stirring/feeding device.





# Pumps

## CONTIPUMPS 250/500 L – 10,000 L

The scansteel foodtech ContiPump series is for less Heavy Duty applications such as, but not limited to, pet food pre-mixes being fed into an emulsifier as well as for various buffer/storage/silo applications. The buffer hopper comes in two versions: a single feeding screw or a twin screw hopper, where one screw feeds/drives the ContiPump and the other prevents/limits bridge building.

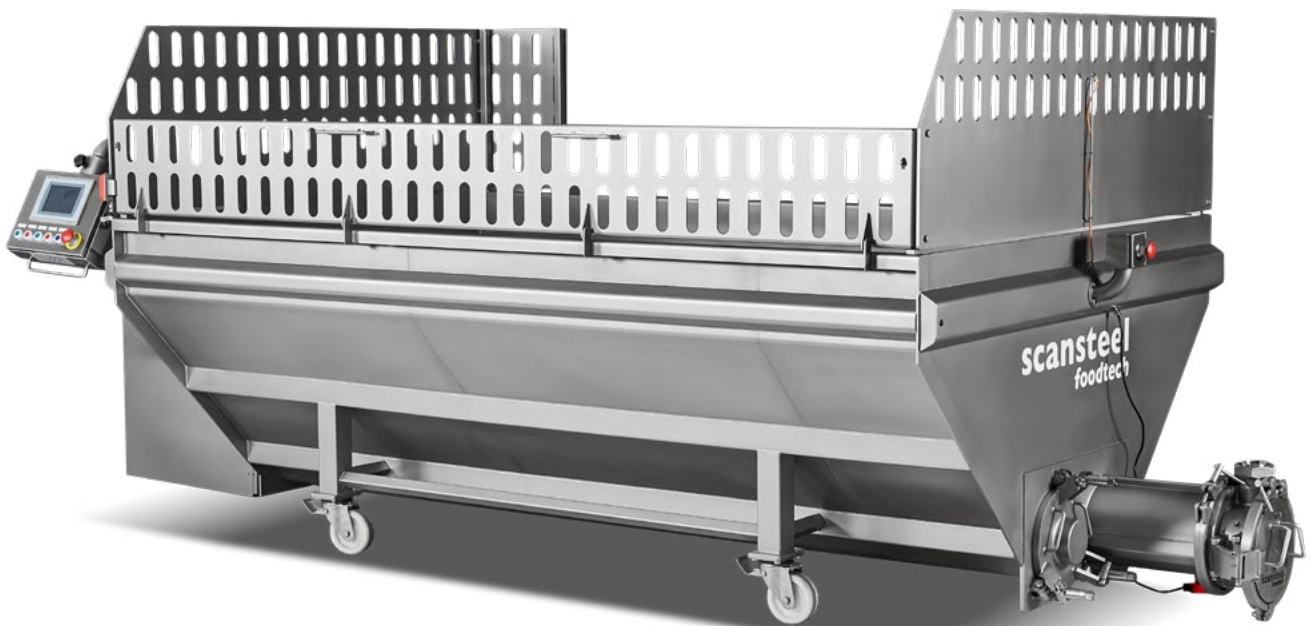

ContiPump 4000/250 Twin Screw shown on above picture. ContiPump 4000/250 Twin Screw shown on above picture. Shown fully assembled ready for production. Shown with all safety rails in position.

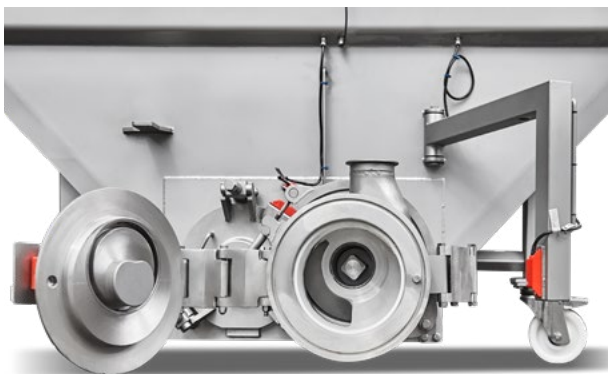

ContiPump pump housing, hinged.



Shown above: Close-up of pump housing and side panel for second screw. Both designed for easy assembly/disassembly.

## CONTIPUMPS 250/500 L – 10,000 L



ContiPump 4000/250 Twin Screw. The operator panel is shown together with a level control.

Inside view of ContiPump 4000/250 Twin Screw. Can also be supplied with top stirring device.



Accessory/cleaning trolley for ContiPump.

# Emulsifiers – Pump Fed

## SCANEMUL 175

The scansteel foodtech scanEmul 175 is an emulsifier for semi-small production capacities ranging from 2000 – 7000 kg/hours. The scanEmul 175 is manufactured with the following motor options: 55 kW, 75 kW, or 90 kW. The scanEmul 175 is, as standard, supplied in two versions, pump fed or hopper fed. For hopper fed applications, the hopper is a stand-alone hopper with a single or a double screw to avoid bridge building of meat raw material pre-mixes.

*On picture (to the right hand side), the scanEmul 175 is shown positioned on a sub-frame to secure good access for mounting/dismounting of knife sets as well as for easy access at periodical maintenance.*



*The scanEmul 175 shown below with a scansteel foodtech ContiPump 250 with Twin Screw to avoid bridge building. Typically, the ContiPump 250 is positioned so either one or two mixers can discharge into the infeed hopper of the ContiPump 250.*

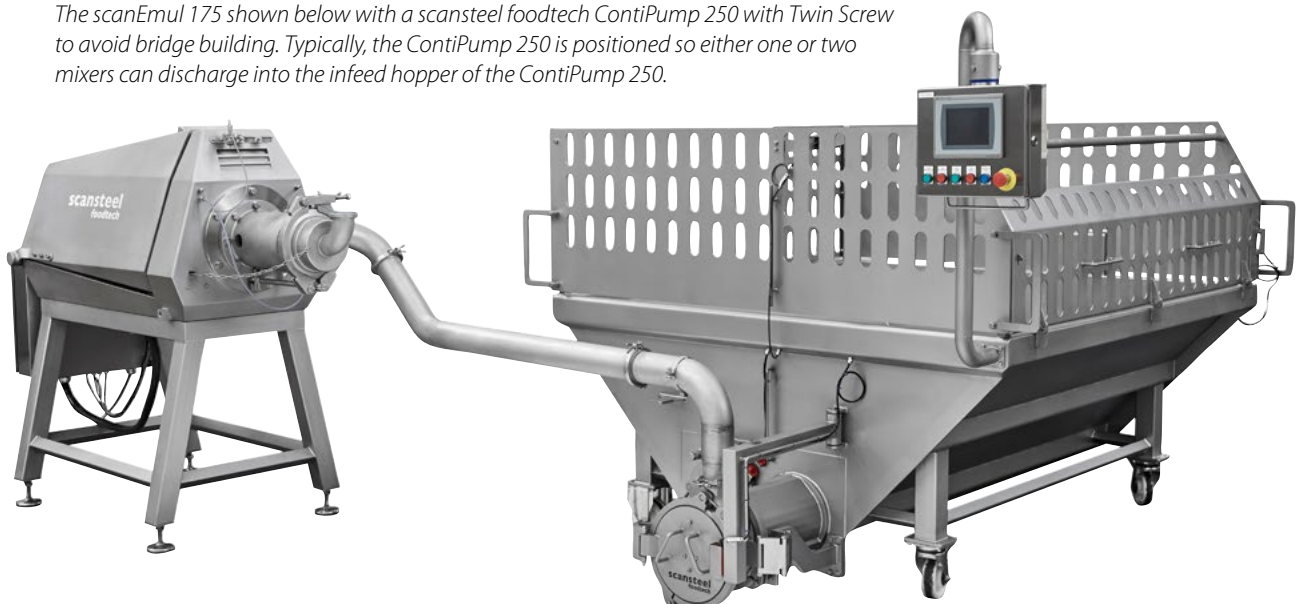

# Emulsifiers – Pump Fed

## SCANEMUL 175

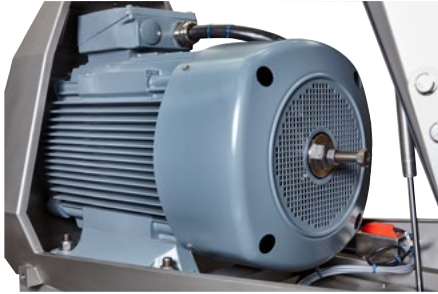

Close-up view with motor access.

scanEmul 175 shown with motor cover in open position for easy access.



Above picture shows triple knife set, loose parts when scanEmul 175 is disassembled, together with tooling for assembly/disassembly.

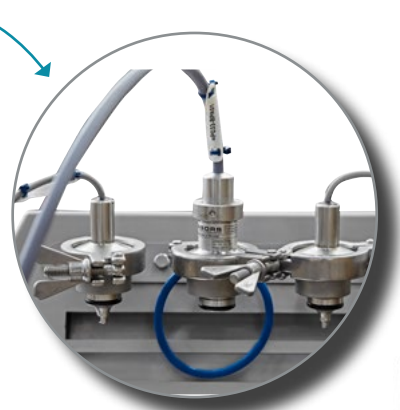

Close-up picture of inlet and outlet temperature sensors as well as pressure transducers.

scanEmul 175 shown disassembled, ready for cleaning, front view.



scanEmul 175 shown disassembled, ready for cleaning, rear view.



# Emulsifiers – Pump Fed

## EMULSIFIER, QUADROCUT 225 / PENTACUT 225



QuadroCut 225.

Globally, the scansteel foodtech QuadroCut 225 / PentaCut 225 emulsifier is the Heavy Duty “Work Horse” among emulsifiers. Danish quality equipment conceived, engineered, and manufactured in Denmark. The QuadroCut 225 / PentaCut 225 emulsifier is a highly reliable, high- and consistent performing emulsifier designed for uniform product quality. The functionality of the machine ensures low running costs just as safe and easy operation.



## EMULSIFIER, QUADROCUT 225 / PENTACUT 225



### HEAVY DUTY CONSTRUCTION FROM THE GROUND UP!

The scansteel foodtech QuadroCut 225 / PentaCut 225 is designed for Heavy Duty applications. The robust frame is designed to easily withstand the forces from electrical motors from 90 kW – 200 kW. All frame and cabinet work is manufactured in stainless steel AISI 304.

### Ultra-Flexible Knife System Set-up

The scansteel foodtech knife set cassettes have been designed so they can be assembled at the meat or pet food processors' workshop by trained technicians. As such, the only thing the machine operators must do is to replace the knife cassette at agreed intervals.

Example: many pet food manufacturers require the final meat and bone product to have a maximum particle size of 1.0 mm or smaller. This can be achieved with the PentaCut 225 knife set-up.

#### Knife Set Combinations:

- PentaCut 225: 5 knives – 4 hole plates
- QuadroCut 225: 4 knives – 3 hole plates
- TrippleCut 225: 3 knives – 2 hole plates
- DoubleCut 225: 2 knives – 1 hole plate



#### TECHNICAL SPECIFICATIONS

- |                               |  |
|-------------------------------|--|
| Motor size:                   | <ul style="list-style-type: none"><li>• Standard range: 90 kW – 200 kW.</li></ul>  |
| Emulsion production capacity: | <ul style="list-style-type: none"><li>• 2000 – 25,000 kg/hour.</li></ul>   |
| Electrical controls:          | <ul style="list-style-type: none"><li>• Allen Bradley operator panel and PLC.</li><li>• Siemens operator panel and PLC</li></ul>   |
| Emulsifier knife set speed:   | <ul style="list-style-type: none"><li>• Frequency controlled speed of 1800 – 3000 rpm.</li><li>• Typically, the most important speed control is given by the infeed pump speed which can be pre-programmed in the control panel of the QuadroCut 225 / PentaCut 225 emulsifier</li></ul> |
| Main bearing:                 | <ul style="list-style-type: none"><li>• Oil filled bearing. Oil cooled.</li></ul>  |

# Heavy Duty Emulsifiers

## MC 250 & MC 300

The industry “Work Horse” – scansteel foodtech emulsifier does it all!

The scansteel foodtech MC 250 & MC 300 emulsifiers have a unique dual feeding/two steps feeding system:

- Stand-alone feeding pump, feeding the lining/housing of the MC 250 & MC 300.
- Feeding/crushing screw, feeding the knife set.

The feeding pump with its own feeding screw with block breaking/bone breaking capabilities force-feeds the scansteel foodtech MC 250 & MC 300 emulsifier lining/housing. Entering the lining/housing, the feeding screw of the MC 250 & MC 300 further force-feeds/grinds any particles, being frozen meat raw materials and/or bones. The feeding screw with its recessed 3-bladed knife distributes any products continuously towards the first hole plate securing optimal cutting/emulsifying effect.



# Heavy Duty Emulsifiers

## MC 250 & MC 300



*Built in oil coolers for gear box dramatically increases life time of the gear box.*

**Designed to emulsify/particle reduce, examples only, products such as:**

- Pre-broken frozen meat raw material blocks
- Fresh meat raw material
- Chicken bones, pork bones, beef bones
- Frozen and fresh combination of above

### Direct Steam Injection System:

Heavy Duty steam valves connected directly in-line in the lining/feeding screw to secure even distribution of steam and subsequently final temperature.

### Knife Set:

The scansteel foodtech MC 250 & MC 300 emulsifiers can be equipped with single, double, or triple knife set. Controllable emulsifying effect with more/less hole plates:

**1 hole plate** = 1 (one) cutting edge against hole plate.

**2 hole plates** = 3 (three) cutting edges against hole plates.

**3 hole plates** = 5 (five) cutting edges against hole plates.

With the wide selection of knives and hole plates, the scansteel foodtech MC 250 & MC 300 emulsifiers ensure you get the final emulsion/final product quality you require.

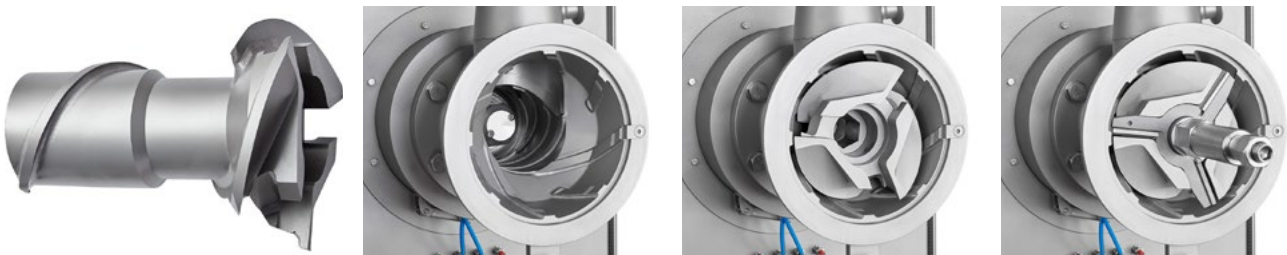

Technical Specifications	Model MC 250	Model MC 300
Capacity (approx.)	4000 – 12,000 kg/hour	6000 – 18,000 kg/hour
Power motor	90-200 kW	90-200 kW
Length	2300 mm	2300 mm
Width	1000 mm	1000 mm
Height	1700 mm	1700 mm
Weight	1.500 kg	2.000 KG

# MEAT-BONE SEPARATOR

## SCANDEBONE 100 & SCANDEBONE 150

### - PUMP FEED SYSTEM

scansteel foodtech scanDebone 100 & scanDebone 150 are high-quality mechanical deboning machines for meat-bone separation for the poultry and processing industries. scanDebone 100 & scanDebone 150 are designed in such a way that the final product temperature increase has been minimized throughout the entire operation.

*The scansteel foodtech scanDebone Series produces an adjustable, very high yield and at the same time it produces a final product with low calcium content in the final poultry and fish raw materials, which supports a high product quality.*



*Top view of scanDebone 100 & scanDebone 150 - Pump Feed System*

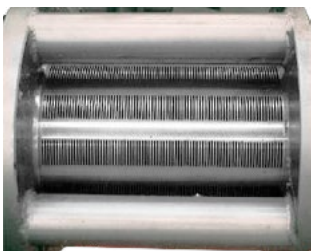

*scanDebone mounted with slit filters.*



*Slit filter seen from inside.*



*Final product: deboned poultry. View 1 (one).*



*Final product: deboned poultry. View 2 (two).*

# Gravy Production Systems

## SCANGRAVY

The scansteel foodtech scanGravy mixing and storage series has been designed to manufacture a wide range of pet food gravies, from light weight gravies to heavy viscous gravies. The scanGravy mixing and storage units are manufactured from 500 L – 6000 L. One entire system is controlled and operated by its own dedicated PLC system with optional software.



*Right hand side: scansteel foodtech mixing unit with high speed dry ingredients addition Venturi system. Left hand side: scansteel foodtech storage unit.*



*scansteel foodtech high speed dry ingredients addition Venturi system. For addition of all kinds of dry "challenging to add" ingredients. Prevents air injection into gravy during production of same.*



*Mixing container designed for heavy viscous gravies/mixtures. The Venturi system in combination with the Heavy Duty mixing agitators ensures a fast processing of a gravy free of lumps. Anti-vortex breakers are standard in all scanGravy mixing tanks. Direct steam injection for temperature control can be added as well.*



*Pumps are positioned/mounted on own frame for easy access at inspection/maintenance, etc. In addition, the pump of the scanGravy mixing unit can be equipped with its own knife system for eliminating lumps in "challenging to produce" gravies.*

# Product Transfer Equipment

## LOGISTIC SYSTEMS

scansteel foodtech manufactures a wide range of:

- Screw conveyors – inclined and horizontal.
- Giraff screw conveyors (horizontal/vertical as one unit)
- Vertical screw conveyors – for mounting directly on outlet of grinders.
- Lifting devices – single/double column.
- Tilt dumpers/swing loaders, hydraulic – single and double column.
- Silo buffer systems from 500 L – 12,000 L.
- Weighing and batching systems – manual or automatic dosing of pre-programmed batch sizes.



Example of inclined belt conveyor with metal detector.



Please note load cells

Weighing, unpacking and batching tables. Table split into two units: one for unpacking of frozen blocks and one for weighing of batches. Table dimensions can be quoted and designed to customer request.



Weighing and batching station, seen from infeed side.



Weighing and batching station, seen from discharge side. Weighing belt positioned on load cells. Drip tray underneath to prevent dripping on floor.

## SCREW CONVEYORS Ø240 - Ø600 MM.

- INCLINED, HORIZONTAL AND VERTICAL SCREW CONVEYORS

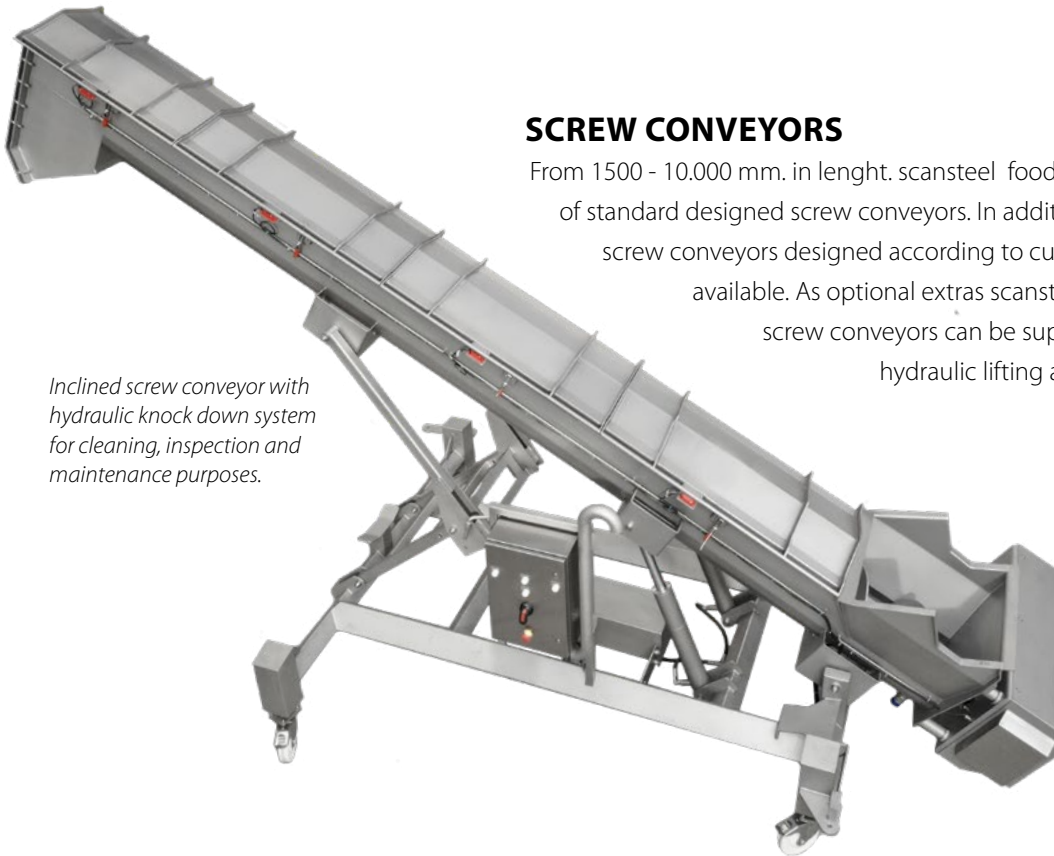

*Inclined screw conveyor with hydraulic knock down system for cleaning, inspection and maintenance purposes.*

### SCREW CONVEYORS

From 1500 - 10.000 mm. in length. scansteel foodtech have a full range of standard designed screw conveyors. In addition 100% tailor-made screw conveyors designed according to customer request is also available. As optional extras scansteel foodtech range of screw conveyors can be supplied with or without hydraulic lifting and lowering systems.

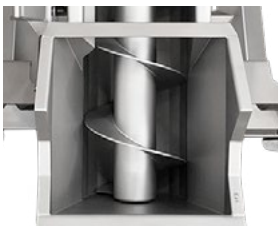

*Example of infeed section for grinder.*

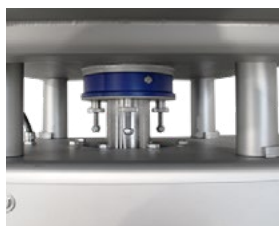

*Heavy Duty shaft bearings shown.*



*Standard screw conveyor electrical/operator panel.*



*Please also note drain/cleaning built-in drain plug.*



*Screw conveyor in knock down position ready for inspector and / or cleaning.*



# Product Transfer Equipment

## SCANGIRAFF

*Example of scansteel foodtech scanGiraff with buffer silo with stirring/feeding device to prevent bridge building.*



*scansteel foodtech standard scanGiraff, showing vertical screw.*



*Top view of scansteel foodtech standard scanGiraff, showing stirring/feeding device.*

# Product Transfer Equipment

## SCANGIRAFF



*scansteel foodtech standard scanGiraff for positioning under a grinder and/or a flaker.*



*scansteel foodtech standard scanGiraff shown in cleaning position. Note the vertical screw is 100% accessible for cleaning (no hidden zones).*



*Large diameter infeed screw in horizontal feed hopper*

# Product Transfer Equipment

## SCANGIRAFF

scanGiraff Ø470mm for heavy duty applications.



*scanGiraff shown in closed position ready for production.*



*scanGiraff shown in cleaning and inspection position.*



*Infeed hopper shown with safety guard/grill in running position.*

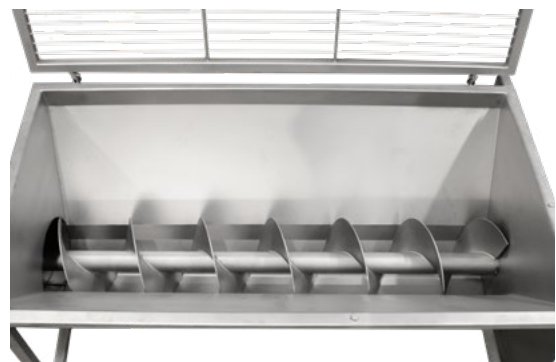

*Infeed hopper shown with safety guard/grill in cleaning and inspections position.*

# Product Transfer Equipment

## SCANLIFT SINGLE COLUMN

- FULL RANGE OF STANDARD LIFTING DEVICES FROM 200 - 300 L TROLLEYS.



scanLift SC 350  
shown with 220 L. trolley

scanLift SC 350  
shown with 300 L. trolley



scanLift SC 350 with 220 L. trolley shown in discharge position. Equipped with discharge chute / non-spill chute.



scanLift SC 350 electrical/operator panel

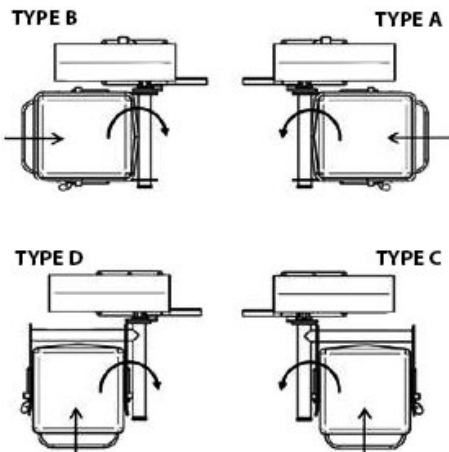

Type A and B Discharge height in mm.	Type C and D Discharge Height in mm.
1400 – 1700	1400 – 1700
1700 – 2000	1700 – 2000
2000 – 2300	2000 – 2300
2300 – 2600	2300 – 2600
2600 – 2900	2600 – 2900
2900 – 3200	2900 – 3200
3200 – 3500	3200 – 3500
3500 – 3800	3500 – 3800
3800 – 4100	3800 – 4100

## SCANLIFT SINGLE COLUMN

- FULL RANGE OF STANDARD LIFTING DEVICES FROM 200 - 300 L TROLLEYS.



Special application  
kettle/bowl

### **i** Please contact us

*Please contact scansteel foodtech for special application/lifting devices for boxes, trolleys and dolav boxes.*

scanLift SC 350  
shown with safety cage



# Product Transfer Equipment

## SCANLIFT DOUBLE COLUMN

- FOR ALL TYPES OF 220 - 300 L. TROLLEYS AND BOXES/DOLAVS BOXES

Double column lifting device  
for plastic/metal crates/boxes.  
- Dual function, shown with  
plastic crates/boxes.



Double column lifting device  
for plastic/metal crates/boxes.  
- Dual function, shown with  
200/300 liter trolley.



Detail showing how forks  
for 200/300 liter trolley work  
combined with plastic/metal  
crates and boxes.

# Product Transfer Equipment

## SCANSWING LOADER

- SCANSTEEL FOODTECH HAS A FULL RANGE OF SWINGLOADERS

*scanSwing loader in down position.*



*scanSwing loader in empty position.*



*Machine feet which can be mounted to the floor.*



*Operator / control panel with emergency stop.*

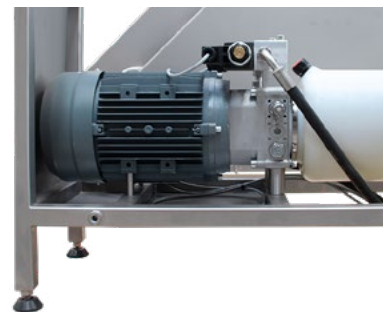

*Inside view of hydraulic system.*

## SCANSTEEL FOODTECH LINE CONTROL SYSTEMS

### LINE CONTROL SYSTEMS

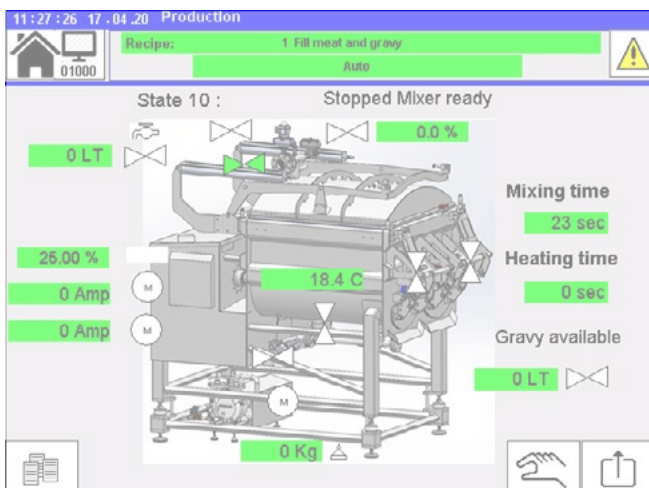
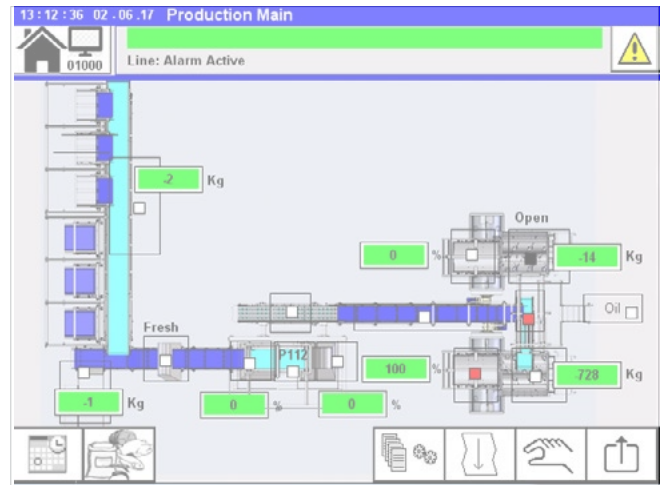

Production

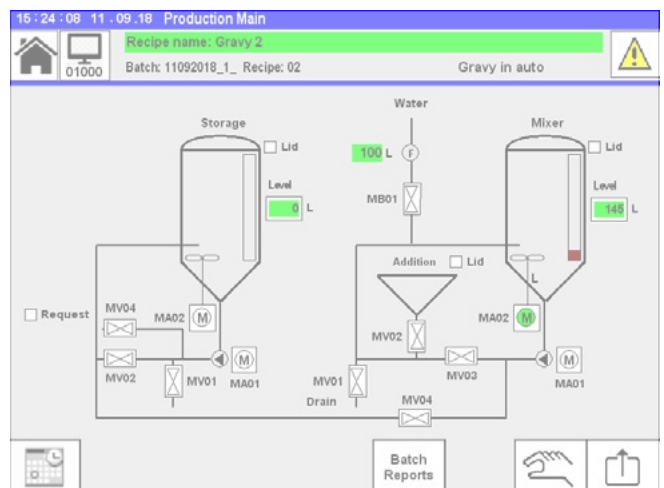

Production Main

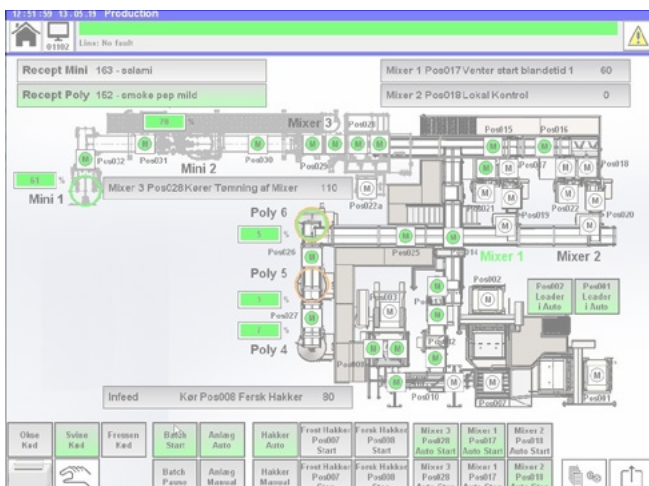

Production



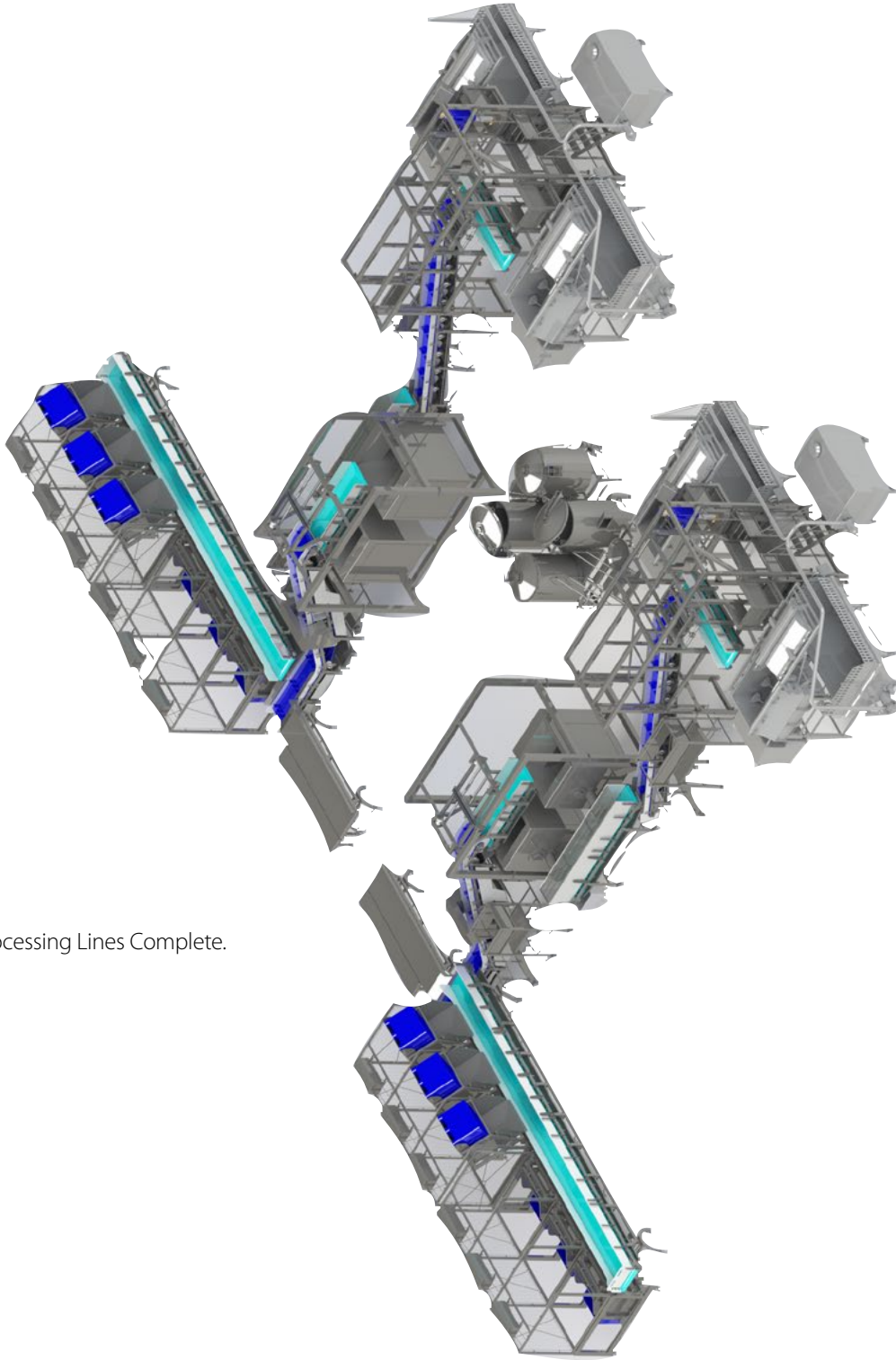

Leader in Processing Lines Complete.

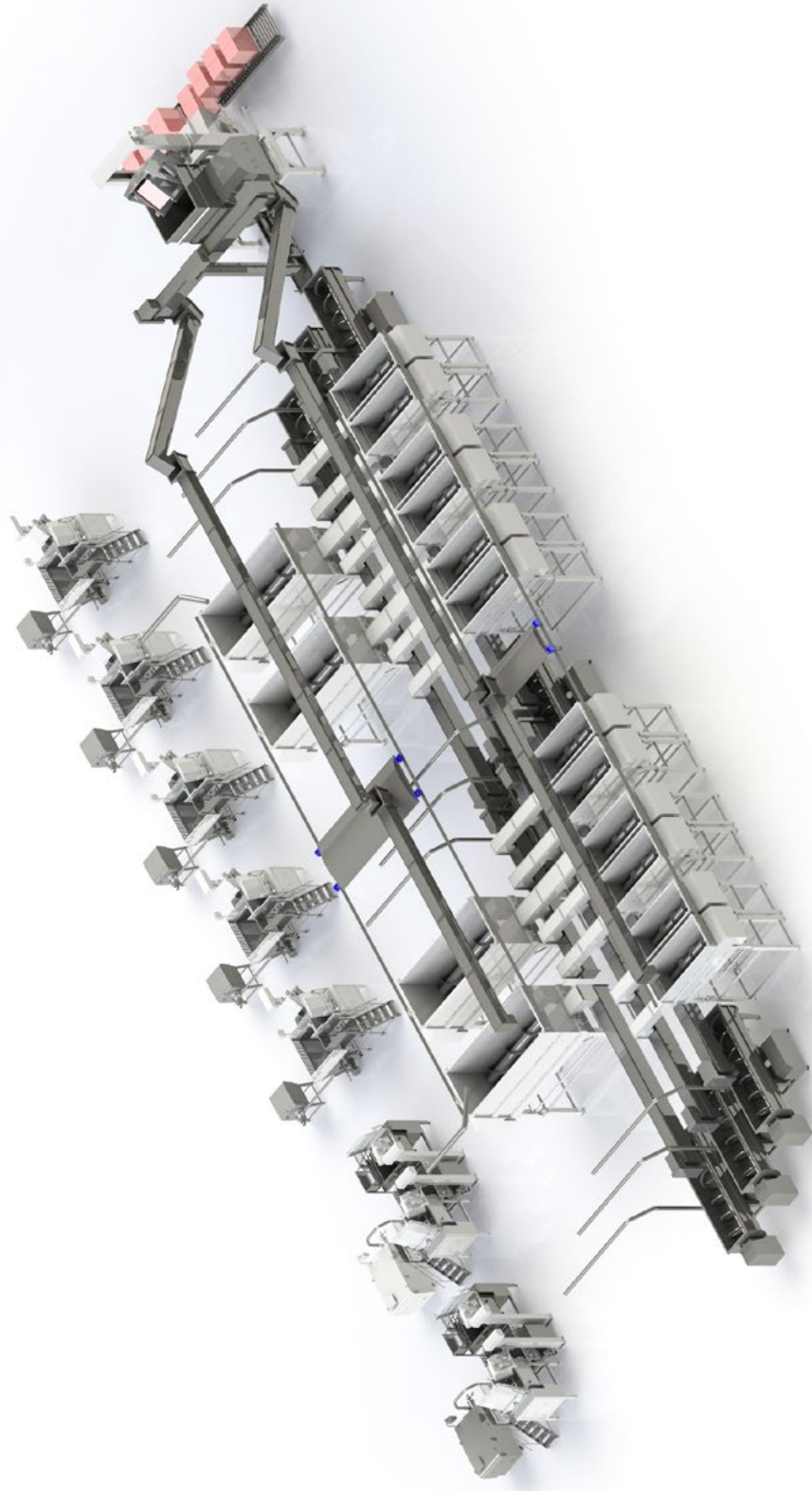

# Layout

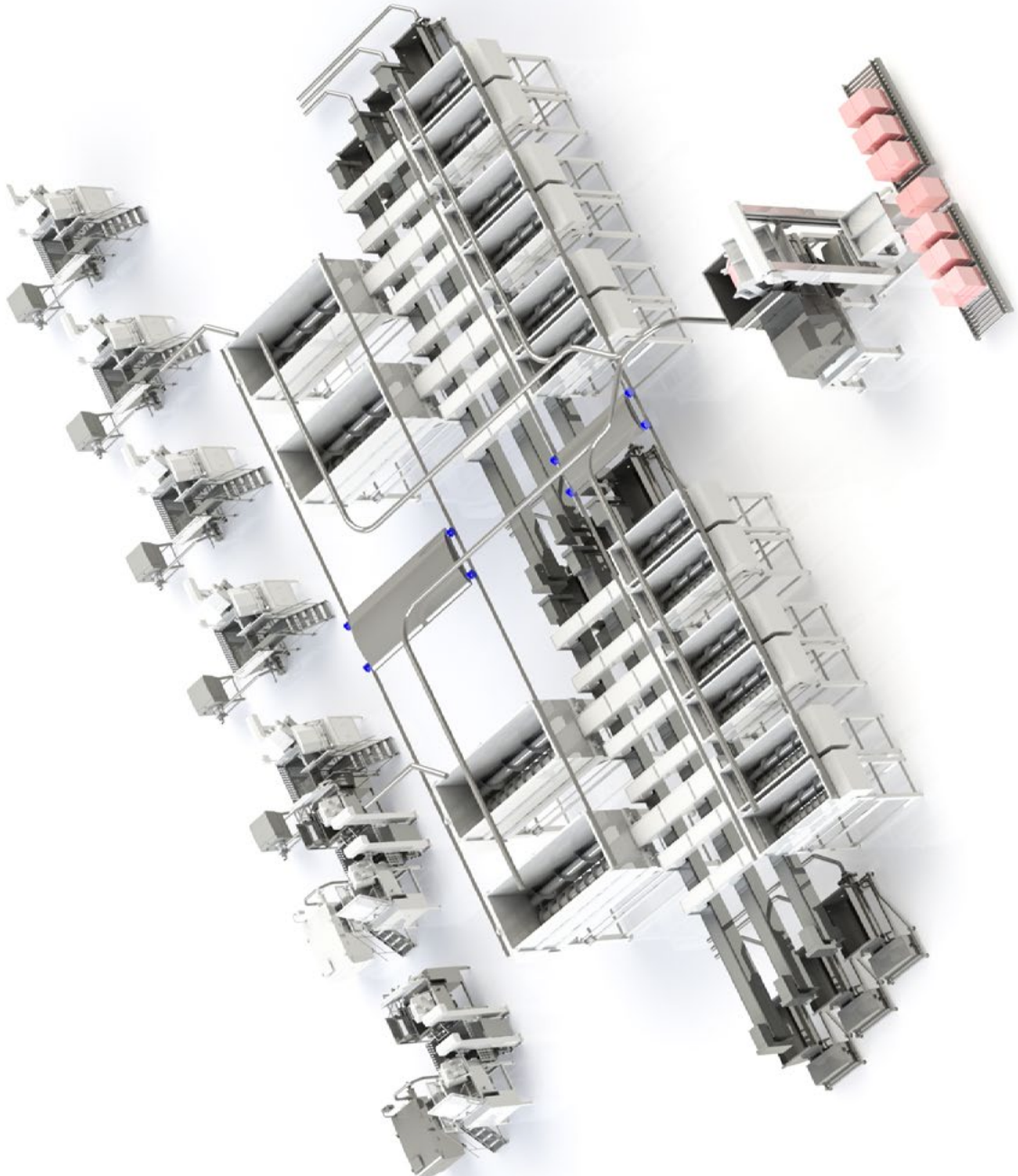

# Our Global Agents & Distributors

**scansteel**<sup>®</sup>  
foodtech



Jamie Culpitt  
Mobile: +61 432 605 627  
E-mail: jamie@focustrading.com.au  
Website: www.focustrading.com.au

Darryl Russ  
Mobile: +61 459 261 052  
E-mail: darryl@focustrading.com.au  
Website: www.focustrading.com.au



Dmitriy Sadovskiy  
Mobile: +375 29 6394354  
E-mail: dir@steiner.by  
Website: www.steiner.by



Harry Jorissen  
Mobile: +31 (0) 6 11867762  
E-mail: harry@vertec.nl  
Website: www.vertec.nl

Harold Swinkels  
Mobile: +31 (0)6 5134 5188  
E-mail: harold@vertec.nl  
Website: www.vertec.nl



Aaron Chabino (Sales)  
Phone: +1 816-880-9321  
E-mail: achabino@scanamcorp.com  
Website: www.scanamcorp.com

Morten Parmo (Sales)  
Phone: +1 614-477-2408  
E-mail: mparmo@scanamcorp.com  
Website: www.scanamcorp.com



Bjarne Hvolbøll  
Mobile: +45 20 31 38 65  
E-mail: bh@nemco.dk  
Website: www.nemco.dk



Bjarne Hvolbøll  
Mobile: +45 20 31 38 65  
E-mail: bh@nemco.dk  
Website: www.nemco.fi

Mr. Pertti Laurila  
E-mail: pla@nemco.fi



Laurent CASTAGNOS  
Phone: +33 (0)6 72 217 663  
E-mail: l.castagnos@bfrgroupe.com  
Website: www.bfrgroupe.com

Vincent Lefebvre  
E-mail: v.lefebvre@bfrgroupe.com

# Our Global Agents & Distributors



Barry France  
Mobile: +44 (0)776 696 5886  
E-mail: bf@selo.com  
Website: www.selo.com

Chris Keenan  
Mobile: +44 (0)788 155 1420  
E-mail: ck@selo.com  
Website: www.selo.com



Raz Pessach  
Mobile: +972 (0) 52 6440 318  
E-mail: raz@pessach.net  
Website: www.pessach.net

Haim Rosenberg  
Mobile: +972 (0) 54 245 1152  
E-mail: haim@pessach.net  
Website: www.pessach.net



Andrea Lazzari  
Phone: +39 045 8350877  
E-mail: andrea@lazzariegquipment.com  
Website: www.lazzariegquipment.com



Harry Jorissen  
Mobile: +31 (0) 6 11867762  
E-mail: harry@vertec.nl  
Website: www.vertec.nl

Harold Swinkels  
Mobile: +31 (0)6 5134 5188  
E-mail: harold@vertec.nl  
Website: www.vertec.nl



Mike Hussey (Sales/Service Engineer)  
Mobile: +64 (021) 895 330  
Email: mike@foodmis.co.nz  
Website: www.foodmis.co.nz



Marcin Królicki CEO  
Mobile +48 601 150 997  
E-mail: m.krolicki@premac.pl  
Website: www.premac.pl

Tomasz Mikołajczak  
Phone: +48 537 721 960  
Email: t.mikolajczak@premac.pl

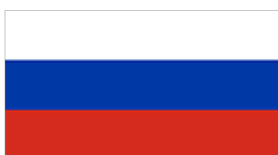

Alexander Bobrow  
E-mail: aab@foodpromtech.ru  
Website: www.foodpromtech.ru

Alexey Grinchuk  
E-mail: ayg@foodpromtech.ru  
Website: www.foodpromtech.ru

# Our Global Agents & Distributors



Rodney Macer Wright  
Mobile: +27 (0) 11 466 0408  
E-mail: rodney@summitpros.co.za  
Website: www.summitpros.co.za



Javier Lopez  
Mobile: +34 667 669 556  
E-mail: javier@picl.es  
Website: www.picl.es



Peo Blomqvist  
Mobile: +46 (0)706 010 111  
E-mail: pb@nemco.se  
Website: www.nemco.se

Bjarne Hvolbøll  
Mobile: +45 20 31 38 65  
E-mail: bh@nemco.dk  
Website: www.nemco.dk



Olexiy B. Kolodchenko  
Mobile: +38 067 5061112  
E-mail: olexiy@steiner.com.ua  
Website: www.steiner.com.ua

Vladimir Litvinets  
Mobile: +38 067 506 37 42  
E-mail: vladimir@steiner.com.ua  
Website: www.steiner.com.ua



Barry France  
Mobile: +44 (0)776 696 5886  
E-mail: bf@selo.com  
Website: www.selo.com

Chris Keenan  
Mobile: +44 (0)788 155 1420  
E-mail: ck@selo.com  
Website: www.selo.com



Aaron Chabino  
Phone: +1 816-880-9321  
E-mail: achabino@scanamcorp.com  
Website: www.scanamcorp.com

Morten Parmo  
Phone: +1 614-477-2408  
E-mail: mparmo@scanamcorp.com  
Website: www.scanamcorp.com





10,450 m2 factory in Denmark, Headquarters of: scansteel foodtech A/S & Koncept Tech ApS

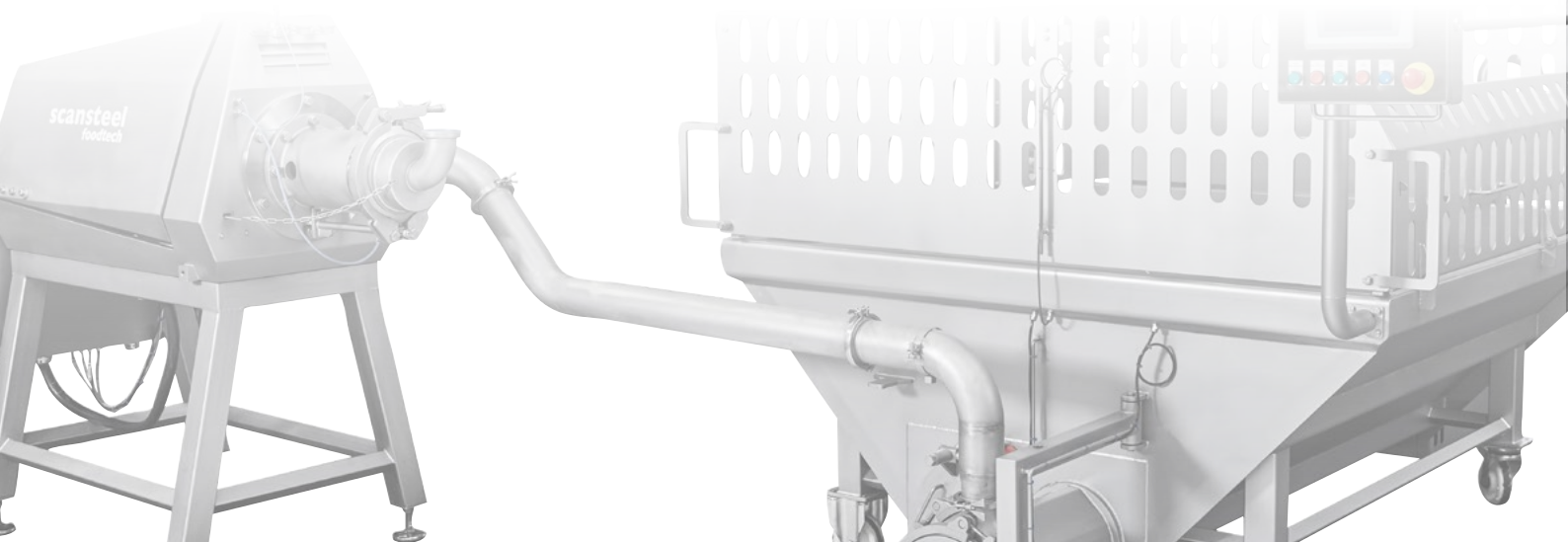

April 2020 Edition

## Follow us on Social Media



scansteel foodtech



scansteel foodtech A/S



scansteel foodtech

**scansteel foodtech A/S**  
Industrivej 6  
4200 Slagelse  
Denmark

Phone: +45 7027 1410

Fax: +45 7027 1411

[www.scansteelfoodtech.com](http://www.scansteelfoodtech.com)