

KNOW HOW IN EMULSIFYING:

With QuadroCut 225 version (4 x knives – 3 hole plates)

With PentaCut 225 version (5 x knives – 4 hole plates)

meat processing / pet food processing



scansteel foodtech

The scansteel foodtech QuadroCut 225 / PentaCut 225 emulsifier is the heavy duty "work horse" among emulsifiers globally. Danish quality equipment, conceived, engineered and manufactured in Denmark. The QuadroCut 225 / PentaCut 225 emulsifier is a highly reliable, high- and consistent performing emulsifier designed for consistent product quality. The functionality of the machine ensures low running costs, safe and easy operation.



Real life benefits from features: Automatic Knife Adjustment system (AKAS)

The unique servo drive with encoder positioning axially moves the rotating shaft, which holds the knives.

Consequently, the bearing and shaft assembly can be positioned with a tolerance of 0.02 mm. The scanLock spring locking system prevents axial movement caused by product flow pressure avoiding hole plate and knives touching dramatically reducing knife and hole plate wear.

During the automatic tightening procedure, the torque controlled servo drive moves the knives until the pre-programmed force against the hole plates has been reached. This value is set as the zero position.

The scanControl software will set the programmed tolerance between the hole plate and knife in question. The AKAS system ensures that product structure (particle size) and final emulsion temperature increase remains constant.

Ultra flexible knife system setup

scansteel foodtech's knife set cassettes has been designed in order that the it can be assembled at the meat- or pet food processors work shop by trained technicians. As such the only thing the machine operators have to do is to replace the knife set cassette at agreed intervals.

Example: many pet food manufactures has a need to expect that the final meat- and bone end product has a maximum particle size of 1,0 mm or smaller. This can be expected with the PentaCut 225 knife set up.

Knife set combinations:

- PentaCut 225 : 5 knives – 4 hole plates
- QuadroCut 225 : 4 Knives – 3 hole plates
- TrippleCut 225 : 3 knives – 2 hole plates
- DoubleCut 2258 : 2 knives – 1 hole plate



Pump fed emulsifier system / pressure controlled startup and shutdown sequence

The QuadroCut 225 / PentaCut 225 emulsifier is a pump fed emulsifier. The startup and shutdown sequence is controlled by the scanControl built-in software package. A pressure transducer monitors the product pressure in front of the first hole plate at the inlet to the knife housing. During startup, the feed pump transport the product through the 4" or 6" pipe line to the QuadroCut 225 / PentaCut 225 inlet. As soon as the pressure reaches the preset startup pressure/value of typically 0.5 – 1.0 bar pressure, the pump stops shortly allowing the QuadroCut 225 / PentaCut 225 to gain speed. The pump then restarts and meat product is then transported to the QuadroCut 225 /

PentaCut 225 being continuously emulsified during this process. A pressure release valve placed at the inlet of the knife housing end will equalize any pressure peaks, eliminating any risk of hole plate damage.

Once the knife housing is empty, pressure will again drop below the pre-set working pressure and the scanControl system will shut down automatically. The pressure transducer also registers unstable product flow, shutting down the system and protecting the QuadroCut 225 / PentaCut 225 against idle runs and unnecessary wear of inserts and hole plates.



HEAVY DUTY CONSTRUCTION FROM THE GROUND UP!

The QuadroCut 225 / PentaCut 225 is designed for heavy-duty applications the robust frame is designed to easily withstand the forces from electrical motors from 90 kW – 200 kW. All frame and cabinetwork is manufactured in stainless steel AISI 304.

Infeed systems for all line applications

scansteel foodtech has a full range of infeed systems available for both high and low viscosity products available such as, but not limited to:

- Full range of pumps for both fresh as well as frozen meat raw materials
- Silos with single- or double infeed screws
- Inline vacuumizers

Typically, the infeed pump, or system, will be controlled by the PLC of the QuadroCut 225 / PentaCut 225 emulsifier.



Designed with full interior access on 3 (three) sides

Highly flexible with a close focus also on preventive maintenance procedures. For regular preventive maintenance operations there are 3 (three) side panels which can easily be removed.

In addition the entire hood (the top part of the cabinet) can be removed.

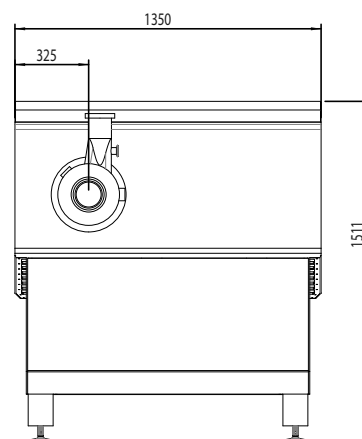
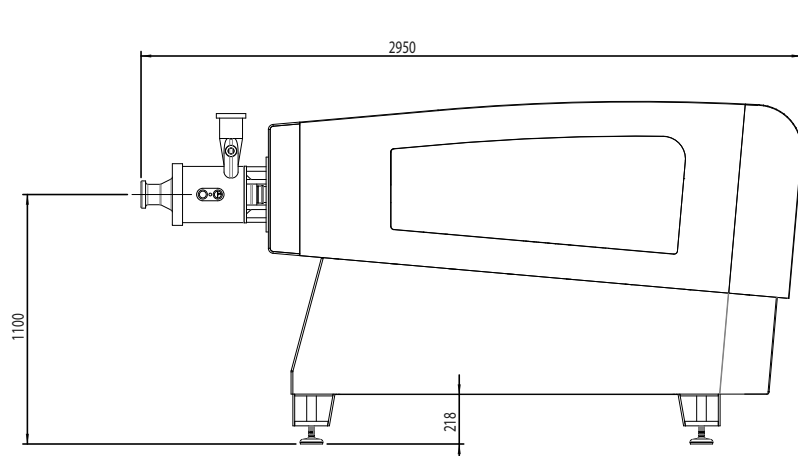

TECHNICAL SPECIFICATIONS

- Motor size :**
- Standard range: 90 kW – 200 kW
- Emulsion production capacity :**
- 2.000 – 25.000 kg/hour
- Electrical controls :**
- Allen Bradley operator panel and PLC
 - Siemens operator panel and PLC
- Emulsifer knife set speed :**
- Frequency controlled speed of 1800 – 3000 rpm
 - Typically the most important speed control will be the infeed pump speed which can be pre-programmed into the control panel of the QuadroCut 225 / PentaCut 225 emulsifier
- Main bearing :**
- Oil filled bearing. Oil cooled

10.450 m² factory in Denmark



HEADQUATER OF:

- **Koncept Tech ApS**
- **scansteel production a/s**
- **scansteel foodtech ApS**

scansteel
foodtech

scansteel foodtech

Industrivej 6
4200 Slagelse
Denmark

Phone: +45 7027 1410
Fax: +45 7027 1411

www.scansteelfoodtech.com